

По вопросам продаж и поддержки обращайтесь:

Алматы (7273)495-231
Ангарск (3955)60-70-56
Архангельск (8182)63-90-72
Астрахань (8512)99-46-04
Барнаул (3852)73-04-60
Белгород (4722)40-23-64
Благовещенск (4162)22-76-07
Брянск (4832)59-03-52
Владивосток (423)249-28-31
Владикавказ (8672)28-90-48
Владимир (4922)49-43-18
Волгоград (844)278-03-48
Вологда (8172)26-41-59
Воронеж (473)204-51-73
Екатеринбург (343)384-55-89
Иваново (4932)77-34-06
Ижевск (3412)26-03-58
Иркутск (395)279-98-46
Казань (843)206-01-48

Калининград (4012)72-03-81
Калуга (4842)92-23-67
Кемерово (3842)65-04-62
Киров (8332)68-02-04
Коломна (4966)23-41-49
Кострома (4942)77-07-48
Краснодар (861)203-40-90
Красноярск (391)204-63-61
Курган (3522)50-90-47
Курск (4712)77-13-04
Липецк (4742)52-20-81
Магнитогорск (3519)55-03-13
Москва (495)268-04-70
Мурманск (8152)59-64-93
Набережные Челны (8552)20-53-41
Нижний Новгород (831)429-08-12
Новокузнецк (3843)20-46-81
Новосибирск (383)227-86-73
Ноябрьск (3496)41-32-12

Омск (3812)21-46-40
Орел (4862)44-53-42
Оренбург (3532)37-68-04
Пенза (8412)22-31-16
Пермь (342)205-81-47
Петрозаводск (8142)55-98-37
Псков (8112)59-10-37
Ростов-на-Дону (863)308-18-15
Рязань (4912)46-61-64
Самара (846)206-03-16
Санкт-Петербург (812)309-46-40
Саранск (8342)22-96-24
Саратов (845)249-38-78
Севастополь (8692)22-31-93
Симферополь (3652)67-13-56
Смоленск (4812)29-41-54
Сочи (862)225-72-31
Ставрополь (8652)20-65-13
Сургут (3462)77-98-35

Сыктывкар (8212)25-95-17
Тамбов (4752)50-40-97
Тверь (4822)63-31-35
Тольятти (8482)63-91-07
Томск (3822)98-41-53
Тула (4872)33-79-87
Тюмень (3452)66-21-18
Улан-Удэ (3012)59-97-51
Ульяновск (8422)24-23-59
Уфа (347)229-48-12
Хабаровск (4212)92-98-04
Чебоксары (8352)28-53-07
Челябинск (351)202-03-61
Череповец (8202)49-02-64
Чита (3022)38-34-83
Якутск (4112)23-90-97
Ярославль (4852)69-52-93

Россия +7(495)268-04-70

Казахстан +7(7172)727-132

Киргизия +996(312)96-26-47

сайт: www.acvatix.nt-rt.ru || эл. почта: atv@nt-rt.ru

ACVATIX™

ТЕХНИЧЕСКИЕ ХАРАКТЕРИСТИКИ НА КОМБИНИРОВАННЫЕ КЛАПАНЫ VPF44



VPF44..

VPF43..

Pressure Independent Control Valves (PICVs)

- With integrated pressure differential controller
- Valve body made of gray cast iron GJL-250 or GJL-400
- Available in the range from DN50 to 200
- Volumetric flow 15 to 280 m³/h nominal, with presetting
- Equipped with pressure test points P/T
- Can be equipped with SAX..P., SAV..P. or SQV..P. electromotoric actuators

Use

- For use in heating, ventilation and air conditioning systems, district heating, as a control valve
- For closed circuits

Type summary

	Product number	Stock number	DN	H ₁₀₀ [mm]	V _{min} [m ³ /h]	V ₁₀₀ [m ³ /h]	ΔP _{min} [kPa]
Standard flow rate	VPF44.50F15	S55266-V136	50	20	2.9	15.9	See page 8
	VPF44.65F25	S55266-V138	65		4.0	28.0	
	VPF44.80F35	S55266-V140	80		5.5	36.7	
	VPF43.100F70	S55266-V106	100	40	12.1	68	
	VPF43.125F110	S55266-V108	125		18.5	110	
	VPF43.150F160	S55266-V110	150	43	25.6	148	
	VPF43.200F210	S55266-V148	200		95	210	
High flow rate	VPF44.50F25	S55266-V137	50	20	4.2	26.2	See page 9
	VPF44.65F35	S55266-V139	65		5.1	35.8	
	VPF44.80F45	S55266-V141	80		7.2	47.9	
	VPF43.100F90	S55266-V107	100	40	14.8	90	
	VPF43.125F135	S55266-V109	125		23	135	
	VPF43.150F200	S55266-V111	150	43	32	195	
	VPF43.200F280	S55266-V149	200		130	280	

Note:

DN = nominal size

H₁₀₀ = nominal stroke

V₁₀₀ = volumetric flow through fully open valve (H₁₀₀)

V_{min} = smallest presettable volumetric flow through fully open valve (H₁₀₀)

ΔP_{min} = **minimum differential pressure required across the valve's control path, so that the difference pressure regulator works reliably**

Ordering

PICV valve, actuator must be ordered separately.

When ordering please specify the quantity, product name and type code.

Example:

Product number	Stock number	Designation
VPF44.65F25	S55266-V138	PICV PN16 with flanged connections

Delivery

- PICVs, actuators and accessories are packed and supplied separately.
- The valves are supplied without counter-flanges and without flange gaskets.

Equipment combinations

Valves				Actuators					
				SAX..P..		SQV..P..		SAV..P..	
		DN	H ₁₀₀ [mm]	Δp_{max} [kPa]	Δp_s [kPa]	Δp_{max} [kPa]	Δp_s [kPa]	Δp_{max} [kPa]	Δp_s [kPa]
Standard flow rate	VPF44.50F15	50	20	600	700	600	700	-	-
	VPF44.65F25	65							
	VPF44.80F35	80							
	VPF43.100F70	100	40	-	-	600	600	600	600
	VPF43.125F110	125							
	VPF43.150F160	150	43	-	-	600	600	600	600
	VPF43.200F210	200							
High flow rate	VPF44.50F25	50	20	600	700	600	700	-	-
	VPF44.65F35	65							
	VPF44.80F45	80							
	VPF43.100F90	100	40	-	-	600	600	600	600
	VPF43.125F135	125							
	VPF43.150F200	150	43	-	-	600	600	600	600
	VPF43.200F280	200							

Note:

H₁₀₀ = nominal stroke

Δp_{max} = maximum permissible differential pressure across valve's control path, valid for the entire actuating range of the motorized valve





Δp_s = maximum permissible differential pressure at which the motorized valve will close securely against the pressure (close off pressure)



Actuator overview

Type	Stock number	Stroke	Positioning force	Operating voltage	Positioning signal	Spring return time	Spring return direction	Positioning time	LED	Manual adjuster	Extra functions
SAX31P03	S55150-A118	20 mm	500 N	AC 230 V	3-position	-	-	30 s	-	Push and fix	1)
SAX61P03	S55150-A114			AC/DC 24 V	DC 0...10 V DC 4...20 mA 0...1000 Ω	-	-	30 s	√		2), 3)
SAX81P03	S55150-A116			3-position	-	-	-	-	-		1)
SQV91P30	S55150-A130	20 mm	1100 N	AC/DC 24 V	3-position	30 s	Pull to open or push to close ⁵⁾	< 120 s ⁵⁾	√	Turn and fix	1), 6)
SQV91P40	S55150-A131	40 mm		AC 230 V ⁴⁾	DC 0...10 V DC 4...20 mA						
SAV31P00	S55150-A121	40 mm	1100 N	AC 230 V	3-position	-	-	120 s	-	Push and fix	1)
SAV61P00	S55150-A119	-	-	AC/DC 24 V	DC 0...10 V DC 4...20 mA 0...1000 Ω	-	-		√	-	2), 3)
SAV81P00	S55150-A120	-	-	3-position	-	-	-		-	1)	
SAX61P03/MO	S55150-A143	20 mm	500 N	AC/DC 24 V	Modbus RTU	-	-	30 s	√	Push and fix	2), 3)

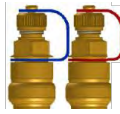
- 1) Optional accessories: Auxiliary switch, potentiometer
- 2) Position feedback, forced control, change of flow characteristic
- 3) Optional accessories: Auxiliary switch, sequence control, acting direction
- 4) Voltage adapter required, order separately
- 5) Selectable
- 6) Position feedback

Accessories

Product numbers	Order number	Designation	
ALE10	ALE10		<p>Electronic manometer excluding measuring lines and measuring tips. Measuring range 0 .. 700 kPa. A differential pressure of more than 1000 kPa will destroy the pressure sensor.</p> <p>For measuring the differential pressure between P₁ and P₂/P₃ of the PICVs (refer to diagram under "Functional principle").</p> <p>Functions of the manometer:</p> <ul style="list-style-type: none"> • Start/stop • Automatic zero position • Backlit display • Display: Out → outside the measuring range • Holding function
ALE11	ALE11		<p>Measuring lines and straight measuring tips for use with Siemens PICVs. Equipped with G 1/8" connection with 2 x 40 mm needles.</p>
ALP45	ALP45		<p>Spare nipples P/T port (set of 2). Set contains 1 piece each with a red and blue ribbon. Port: External threads G 1/8 " to ISO 228 Connection to valve body: G 1/4 " to ISO 228, including O-ring Length: 40 mm</p>
ALP46 (only for p ₁ , p ₃)	S55264-V115		<p>Blanking plugs for P/T ports Connection to valve body: G 1/4" to ISO 228, inclusive O-ring</p>

Product numbers	Order number	Designation	
ALP47 (only for p ₁ , p ₃)	S55264-V116		Drain ball valve inclusive O-ring Port: External threads G ½" to ISO 228 Connection to valve body: G ¼" to ISO 228, inclusive O-ring Length: 48 mm
ALP48 (only for p ₁ , p ₃)	S55264-V117		Combined P/T port and drain ball valve with blue ribbon Port: External threads G ½" to ISO 228 Connection to valve body: G ¼" to ISO 228, inclusive O-ring Length: 80 mm
ALP49	S55264-V118		Long P/T ports (set of 2 pieces) Set contains 1 piece each with a red and blue ribbon. Port: External threads G ½" to ISO 228 Connection to valve body: G ¼" to ISO 228, inclusive O-ring Length: 120 mm

Technical design

VPF43..

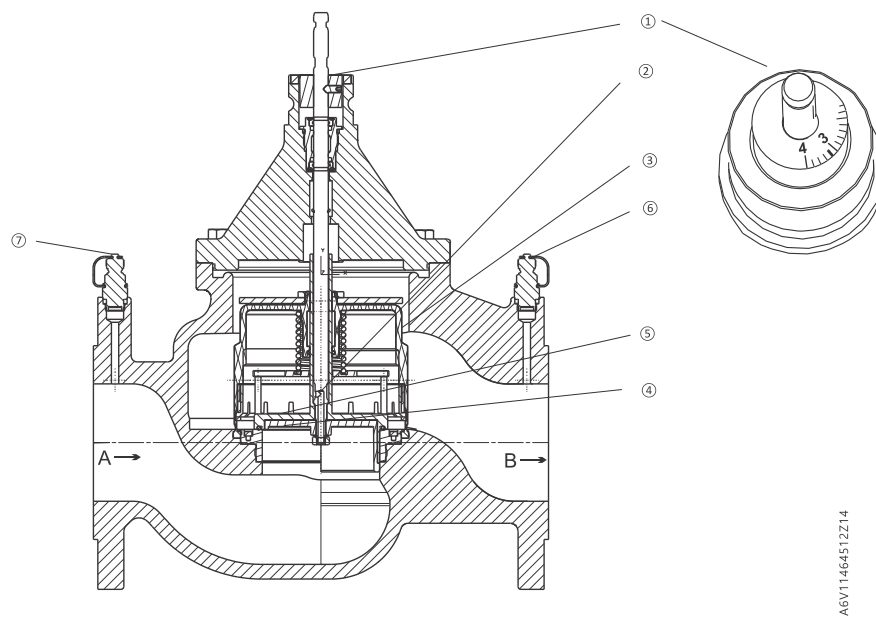

A6V1146451Z214

1	Ring with dial for presetting
2	Aperture for the differential pressure controller is linked with outlet port B
3	Differential pressure controller
4	Plug with variable presetting opening
5	Control valve
6	Pressure test point (P/T) at outlet port B, blue ribbon, p ₃
7	Pressure test point (P/T) at inlet port A, red ribbon, p ₁
A	Inlet port A
B	Outlet port B

VPF44..

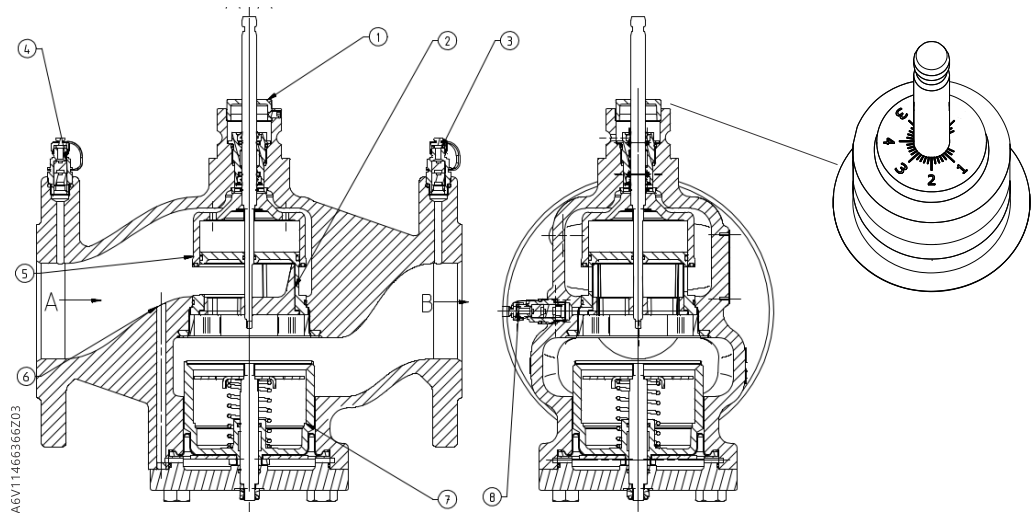

1	Ring with dial for presetting
2	Seat with variable presetting opening
3	Pressure test point (P/T) at outlet, blue ribbon, p_3
4	Pressure test point (P/T) at inlet port A, red ribbon, p_1
5	Control valve
6	Aperture for the differential pressure regulator is linked with inlet port A
7	Differential pressure controller - DPR
8	Pressure test point (P/T) at outlet of control valve, blue ribbon, p_2
A	Inlet port A
B	Outlet port B

Functional principle

The PICVs VPF43../VPF44.. combine three functions:

- a control valve for controlling the volumetric flow
- an adjustable mechanism with a dial for a presettable maximum volumetric flow
- a DPR for balancing pressure fluctuations in the hydraulic system respectively across the control valve

The mechanical series-connected differential pressure controller keeps the differential pressure ($p_1 - p_2$) constant across the control valve and thus the set volumetric flow too. The desired maximum volumetric flow can be preset with the adjusting mechanism. The controller (not shown) and the actuator regulate the volumetric flow and consequently the desired temperature in buildings, rooms or zones.

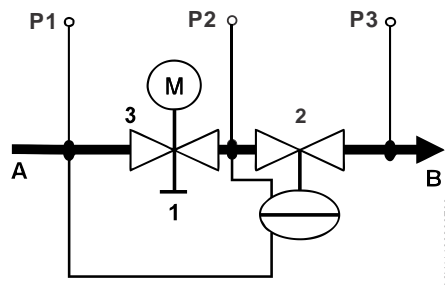

- A Inlet medium (inlet port A)
- B Outlet medium (outlet port B)
- 1 Ring with dial for presetting
- 2 Differential pressure controller (DPR)
- 3 Control valve with mounted actuator

p ₁	P/T port with red ribbon, pressure test point at inlet port A of PICV
p ₂	P/T port with blue ribbon, pressure at outlet port of control valve (3)
p ₃	P/T port with blue ribbon, pressure test point at outlet port B of PICV

Medium flow

The medium entering the PICV (inlet port A) first passes through the control valve (3) with a **linear characteristic and a stroke of 20 mm (DN 50...80) respectively 40 mm (DN 100 - 150) and 43mm (DN 200)**. The actuator (not shown here) opens and accurately positions the control valve. Then, the medium flows through the variable presetting opening which is connected to the ring with dial (1) for presetting the desired maximum volumetric flow.

Before leaving the PICV (outlet port B), the medium passes through a built-in mechanical differential pressure controller. This differential pressure controller is the heart of the PICV and ensures that the selected volumetric flow is maintained across the whole working range and independent of the inlet pressure p₁.

Pressure test points

The PICV VPF43.. is equipped with two pressure test points (p₁, p₃) for measuring and monitoring the differential pressure across the valve during commissioning. The PICV VPF44.. is equipped with three pressure test points (p₁, p₃, p₂) for measuring and monitoring the differential pressure across the control valve and PICV during commissioning. For that purpose, the electronic manometer ALE10 can be used.

Manual control

Only possible with mounted actuator.

Advantages

The advantages of PICVs are that:

- Once the flow limiter is set to design flow, the hydraulic circuit self balances, even when changes to the system are made, such as additions.
- For any heat demand the PICV with mounted actuator can be set to the desired volumetric flow and will be relatively constant regardless of pressure fluctuations in the system.

Constant flow regardless of pressure changes in the system reduces hydraulic interdependence and leads to a more stable control.

Sizing

Engineering Example

$$\dot{V} = \frac{Q[\text{kW}] \cdot 1000}{1.163 \cdot \Delta T[\text{K}]} \left[\frac{\text{l}}{\text{h}} \right]$$

Basis of design

1. Determine heat demand Q [kW]
2. Determine temperature spread ΔT [K]
3. Calculate volumetric flow
4. Select suitable PICV VPF43../VPF44..
5. Determine dial setting using volumetric flow/dial presetting tables, see below.

Example

1. Heat demand Q = 150 kW
2. **Temperature spread $\Delta T = 6$ K**
3. Volumetric flow

$$\dot{V} = \frac{150 \text{ kW} \cdot 1000}{1.163 \cdot 6 \text{ K}} = 21'654 \text{ l/h} = 21.6 \text{ m}^3 / \text{h}$$

Hint: You can also determine the volumetric flow using the valve slide rule.

4. Select PICV VPF44.
Ideally, PICVs should be selected such that they operate at about 80 % of their maximum flow, enabling them to deliver spare capacity, if required.
Selections:

VPF44.65F25 $\Delta p_{\min} = 22 \text{ kPa}$
 VPF44.65F35 $\Delta p_{\min} = 42.6 \text{ kPa}$

- Determine dial setting using volumetric flow/dial presetting tables:
 VPF44.65F25 Volumetric flow 21.6 m³/h
 Dial setting 3.3
 VPF44.65F35 Volumetric flow 21.6 m³/h
 Dial setting 2.7

Volumetric flow/dial presetting

Tables to determine the dial setting for a desired volumetric flow.

Δp_{\min} [kPa] based on volumetric flow; interpolate missing values.

The presetting tables below indicate the expected nominal volumetric flow. During commissioning, check whether current pre-settings correspond to planned design. Further adjustment of pre-settings may be required to achieve needed volumetric flow.

	Presetting range linear to VDI/VDE 2173
	Presetting range linear
	Presetting range not permitted

Low flow rate

VPF44.50F15														15 m ³ /h nominal							
\dot{v} [m ³ /h]				2.9	3.7	4.4	5.0	5.8	6.6	7.5	8.3	9.4	10.5	11.8	13.2	13.9	14.7	15.1	15.4	15.6	15.9
Dial	Min.	0.2	0.4	0.6	0.8	1	1.2	1.4	1.6	1.8	2	2.2	2.4	2.6	2.8	3	3.2	3.4	3.6	3.8	Max.
Δp_{\min} [kPa]				9.6	9.6	9.6	9.6	10.1	10.5	10.8	11.1	11.9	12.7	13.4	14.1	15.1	16.0	17.4	18.8	20.1	21.4

VPF44.65F25														25 m ³ /h nominal							
\dot{v} [m ³ /h]				4.0	4.9	5.8	6.7	7.6	8.5	9.8	11.0	12.4	13.7	15.5	17.4	18.9	20.5	23.0	25.6	27.0	28.0
Dial	Min.	0.2	0.4	0.6	0.8	1	1.2	1.4	1.6	1.8	2	2.2	2.4	2.6	2.8	3	3.2	3.4	3.6	3.8	Max.
Δp_{\min} [kPa]				25.3	26.7	25.4	24.2	25.0	25.8	25.0	24.3	23.4	22.6	23.1	23.6	23.9	24.2	23.1	22.1	22.1	22.0

VPF44.80F35														35 m ³ /h nominal							
\dot{v} [m ³ /h]				5.5	6.8	8.1	9.3	10.6	12.0	13.5	15.0	17.1	19.1	21.0	22.9	25.7	28.5	30.9	33.2	34.7	36.7
Dial	Min.	0.2	0.4	0.6	0.8	1	1.2	1.4	1.6	1.8	2	2.2	2.4	2.6	2.8	3	3.2	3.4	3.6	3.8	Max.
Δp_{\min} [kPa]				10.2	12.2	10.4	12.0	12.2	12.3	12.4	12.3	12.4	12.4	14.2	15.9	15.5	16.1	17.3	18.5	17.9	18.0

VPF43.100F70														70 m ³ /h nominal							
\dot{v} [m ³ /h]				12.1	15	18	21	23	25	28	30	32	35	38	40	43	47	51	56	62	68
Dial	Min.	0.2	0.4	0.6	0.8	1	1.2	1.4	1.6	1.8	2	2.2	2.4	2.6	2.8	3	3.2	3.4	3.6	3.8	Max.
Δp_{\min} [kPa]				19.0	19.0	20.0	20.5	20.8	21.2	21.7	22.0	22.5	23.2	23.8	24.3	25.0	26.6	28.2	30.2	32.6	35

VPF43.125F110														110 m ³ /h nominal							
\dot{v} [m ³ /h]				18.5	23	28	33	37	42	46	51	55	60	65	69	74	80	85	92	99	110
Dial	Min.	0.2	0.4	0.6	0.8	1	1.2	1.4	1.6	1.8	2	2.2	2.4	2.6	2.8	3	3.2	3.4	3.6	3.8	Max.
Δp_{\min} [kPa]				16.0	16.0	16.0	16.4	16.8	17.2	17.6	18.0	18.5	19.2	19.8	20.3	21.0	23.3	25.3	28.0	30.7	35

VPF43.150F160														160 m ³ /h nominal							
\dot{v} [m ³ /h]				25.6	31	38	44	51	57	63	72	76	82	89	96	104	111	120	128	137	148
Dial	Min.	0.2	0.4	0.6	0.8	1	1.2	1.4	1.6	1.8	2	2.2	2.4	2.6	2.8	3	3.2	3.4	3.6	3.8	Max.
Δp_{\min} [kPa]				21.0	21.0	21.0	21.2	21.4	21.6	21.7	22.0	23.0	24.5	26.3	28.0	30.0	30.8	31.8	32.7	33.8	35

VPF43.200F210														210 m ³ /h nominal							
\dot{v} [m ³ /h]						95	100	105	112	118	124	132	140	149	157	165	173	182	192	200	210
Dial	Min.	0.2	0.4	0.6	0.8	1	1.2	1.4	1.6	1.8	2	2.2	2.4	2.6	2.8	3	3.2	3.4	3.6	3.8	Max.
Δp_{\min} [kPa]						11	12	12	14	15	16	17	19	21	22	24	26	27	29	30	32

High flow rate

VPF44.50F25																	25 m ³ /h nominal				
\dot{v} [m ³ /h]				4.2	5.6	6.6	7.6	8.8	10.0	11.4	12.7	14.3	15.9	18.2	20.5	21.9	23.3	24.0	24.8	25.5	26.2
Dial	Min.	0.2	0.4	0.6	0.8	1	1.2	1.4	1.6	1.8	2	2.2	2.4	2.6	2.8	3	3.2	3.4	3.6	3.8	Max.
Δp_{min} [kPa]				22.3	25.0	24.4	23.8	30.2	36.6	37.0	37.4	37.8	38.1	40.8	43.6	45.1	46.6	48.0	49.5	51.1	52.6

VPF44.65F35																	35 m ³ /h nominal				
\dot{v} [m ³ /h]				5.1	6.4	7.7	9.1	9.9	10.7	12.5	14.3	16.3	18.4	20.5	22.6	24.7	26.8	30.4	34.0	34.6	35.8
Dial	Min.	0.2	0.4	0.6	0.8	1	1.2	1.4	1.6	1.8	2	2.2	2.4	2.6	2.8	3	3.2	3.4	3.6	3.8	Max.
Δp_{min} [kPa]				26.9	27.4	27.6	27.8	27.3	26.8	27.1	27.4	28.1	28.8	29.9	31.0	32.5	34.0	36.5	39.0	40.8	42.6

VPF44.80F45																	45 m ³ /h nominal				
\dot{v} [m ³ /h]				7.2	9.3	10.2	11.8	13.3	14.9	17.1	19.4	21.8	24.3	27.2	30.1	32.9	35.8	38.6	41.4	44.4	47.9
Dial	Min.	0.2	0.4	0.6	0.8	1	1.2	1.4	1.6	1.8	2	2.2	2.4	2.6	2.8	3	3.2	3.4	3.6	3.8	Max.
Δp_{min} [kPa]				16.2	18.6	17.7	19.1	19.6	20.1	20.6	19.9	22.0	23.0	24.3	25.6	25.1	25.2	27.6	30.0	33.9	36.4

VPF43.100F90																	90 m ³ /h nominal				
\dot{v} [m ³ /h]				14.8	19	22	26	29	32	35	38	42	44	48	52	56	61	66	73	81	90
Dial	Min.	0.2	0.4	0.6	0.8	1	1.2	1.4	1.6	1.8	2	2.2	2.4	2.6	2.8	3	3.2	3.4	3.6	3.8	Max.
Δp_{min} [kPa]				29.0	29.0	30.0	31.3	32.2	33.1	34.1	35.0	37.2	38.3	40.6	42.8	45.0	49.4	53.8	60.0	67.1	75

VPF43.125F135																	135 m ³ /h nominal				
\dot{v} [m ³ /h]				23	29	36	42	48	53	59	64	70	76	81	87	93	100	107	114	122	135
Dial	Min.	0.2	0.4	0.6	0.8	1	1.2	1.4	1.6	1.8	2	2.2	2.4	2.6	2.8	3	3.2	3.4	3.6	3.8	Max.
Δp_{min} [kPa]				27.0	27.0	27.0	27.4	27.9	28.2	28.6	29.0	29.8	30.7	31.3	32.2	33.0	36.3	39.7	43.0	46.8	53

VPF43.150F200																	200 m ³ /h nominal				
\dot{v} [m ³ /h]				32	40	48	57	64	72	80	88	96	104	112	121	131	141	152	165	178	195
Dial	Min.	0.2	0.4	0.6	0.8	1	1.2	1.4	1.6	1.8	2	2.2	2.4	2.6	2.8	3	3.2	3.4	3.6	3.8	Max.
Δp_{min} [kPa]				33.0	33.0	33.0	33.2	33.4	33.6	33.8	34.0	36.2	38.5	40.7	43.2	46.0	49.0	52.2	56.1	60.0	65

VPF43.200F280																	280 m ³ /h nominal				
\dot{v} [m ³ /h]						130	137	145	153	162	170	180	189	199	209	220	232	243	256	267	280
Dial	Min.	0.2	0.4	0.6	0.8	1	1.2	1.4	1.6	1.8	2	2.2	2.4	2.6	2.8	3	3.2	3.4	3.6	3.8	Max.
Δp_{min} [kPa]						31	32	33	35	38	41	45	49	53	57	61	65	69	73	75	78

Product documentation

Topic	Title	Document ID:
Mounting and installation	VPF43../VPF44.. Mounting instructions	A6V11464512
Product environmental compatibility	VPF44.. The product environmental declaration A5W00090351A contains data on environmentally compatible product design and assessments (RoHS compliance, materials composition, packaging, environmental benefit, disposal).	-
	VPF43.. The product environmental declaration CE1E4315en contains data on environmentally compatible product design and assessments (RoHS compliance, materials composition, packaging, environmental benefit, disposal).	-
EU Conformity (CE)	VPF44..	A5W00099503A
	VPF43..	CE1T4315xx

Notes

Security

	<p>⚠ CAUTION</p>
	<p>National safety regulations Failure to comply with national safety regulations may result in personal injury and property damage.</p> <ul style="list-style-type: none"> Observe national provisions and comply with the appropriate safety regulations.

Engineering

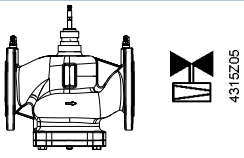
Valve	Symbols / Direction of flow VPF44..	Flow in control mode	Valve stem	
			retracts	extends
PICV		variable	closes	opens

	<p>⚠ WARNING</p>
	<p>The direction of flow indicated (arrow on the valve body) is mandatory!</p> <ul style="list-style-type: none"> The valves should preferably be mounted in the return pipe where temperatures are lower, and where the sealing gland is less affected by strain. Valve's factory default position = CLOSED.

Symbol

Symbol used in catalogs and application descriptions	Symbol used in diagrams
	There are no standard symbols for PICVs in diagrams

Recommendation

- A strainer or dirt trap should be fitted upstream of the valve to enhance reliability and service life.
- Remove dirt, welding beads etc. from valves and pipes.
- Do not insulate the actuator bracket, as air circulation must be ensured!

Mounting

- PICV and actuator can easily be assembled on site. Neither special tools nor adjustments, besides the presetting are required.
- The valve is supplied with Mounting Instructions A6V11464512.

Orientation

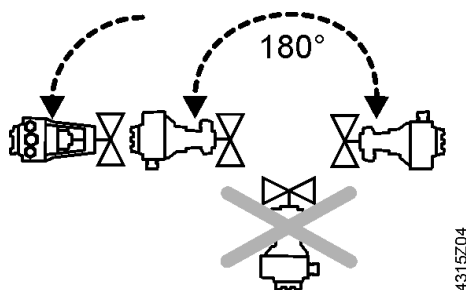

Direction flow

Pay attention to the valve's flow direction symbol during mounting.

Installation

Presetting

It is recommended to mount the actuator before the presetting is made.

1. Mount actuator and fix valve neck coupling
2. Mount valve stem coupling and tighten slightly
3. Make presetting **according to table under "Volumetric flow / dia presetting"**. **Do NOT** adjust presetting to a dial reading lower than "0.6".
4. Tighten stem coupling

VPF43.. ( 8 mm, \dot{V} [m³/h])

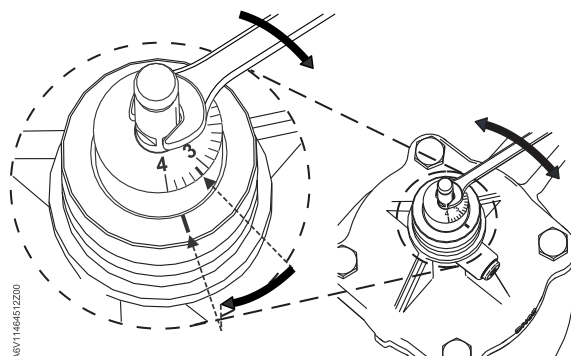

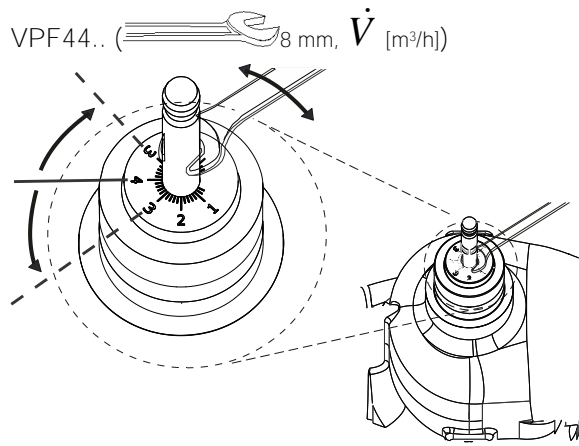

VPF44.. has a symmetric pre-setting scale for easy commissioning. Identical pre-settings positions give identical flow rate.

Valve characteristic

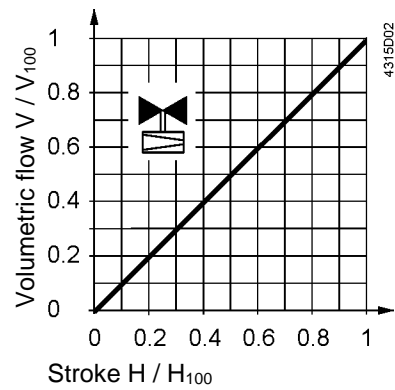

Working pressure and medium temperature

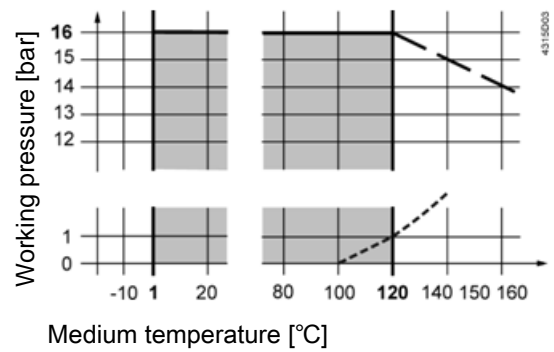

Working pressure and medium temperature staged as per ISO 7005.

	<p>⚠ WARNING</p> <p>Current local legislation must be observed.</p>
---	--

Commissioning

	NOTICE
	<ul style="list-style-type: none">• Consequences The valves must be commissioned with the actuator correctly fitted. Strong pressure impacts can damage closed PICVs.• The valves must be open when flushing or pressure testing the system. Strong pressure impacts can damage closed PICVs.• Differential pressure P_{max} across the valve's control path is not allowed to exceed 600 kPa.• Valve's factory default position = CLOSED.

Maintenance

The VPF43..PICVs are maintenance-free. Maintenance for VPF44.. allows exchange of the pressure control part (DPR).

	⚠ WARNING
	<p>When performing service work on the valve or actuator:</p> <ul style="list-style-type: none">• Switch off the pump and disconnect power supply.• Close the shut-off valves in the piping network.• Fully reduce pressure in the piping network and allow the pipes to cool down completely.• Remove the electrical connections only if necessary.

Sealing gland

The stem sealing gland cannot be exchanged. In case of leakage the whole valve must be replaced.

Disposal

	<p>The valve is considered an electronic device for disposal in accordance with the European Guidelines and may not be disposed of as domestic garbage.</p> <ul style="list-style-type: none">• Dispose of the valve through channels provided for this purpose.• Comply with all local and currently applicable laws and regulations.
---	---

Warranty

Technical data on specific applications are valid only together with Siemens products listed under "Equipment combinations". Siemens rejects any and all warranties in the event that third-party products are used.

Functional data			
PN class	PN16 as per EN 1333		
Permissible operating pressure	1600 kPa (16 bar) as per ISO 7628 / EN 1333		
Valve characteristic	Linear as per VDI / VDE 2173		
Leakage rate	Class IV (0...0.01 % of volumetric flow V_{100}) to EN 1349		
Operating direction	Bi-directional		
Permissible media	Low temperature hot water, medium temperature hot water, chilled water, water with anti-freeze Recommendation: water treatment to VDI 2035		
Medium temperature	DN 50-150: 1...120 °C DN 200: 1...110 °C		
Rangeability	1: 100		
Average flow accuracy	± 10%	from ΔP_{min} up to 70 kPa from ΔP_{min} up to 105 kPa from ΔP_{min} up to 600 kPa	(DN 50...80) (DN 100...50) (DN 200)
	± 5%	from 70...600 kPa from 105...600 kPa	(DN 50...80) (DN 100...150)
Nominal stroke	DN50, 65, 80: 20 mm DN100, 125: 40 mm DN150, 200: 43 mm		
Low-noise operation	To operate the valve at a low noise level, a differential pressure of 150kPa should not be exceeded.		

Materials	
Valve body	DN 50...80, DN125: Gray cast iron GJL-250 DN 100, 150, 200: Nodular cast iron GJS-400
Stem, spring	Stainless steel
Trim	Brass (DZR)
Regulator	Stainless steel
Seals	EPDM

Norms and standards		
VPF43.. EU Conformity (CE)	CE1T4315xx ¹⁾	
VPF44.. EU Conformity (CE)	A5W00099503A	
EAC conformity (only for VPF43..)	VPF43.. Eurasia conformity	
Pressure Equipment Directive	PED 2014/68/EU	
Pressure accessories	Scope: Article 1, section 1 Definitions: Article 2, section 5	
Fluid group 2	DN 50, DN 200 ³⁾	Without CE-marking as per article 4, section 3 (sound engineering practice) ¹⁾
	DN 65...150	Category I, module A, with CE-marking as per article 14, section 2
Environmental conformity	The product environmental declaration CE1E4315en ²⁾ (for VPF43..), A5W00090351A ²⁾ (for VPF44..) contain data on environmentally compatible product design and assessments (RoHS compliance, materials composition, packaging, environmental benefit, disposal).	

General ambient conditions			
	Operation EN 60721-3-3	Transport EN 60721-3-2	Storage EN 60721-3-1
Environmental conditions	Class 3K5	Class 2K3	Class 1K3
Temperature	1...55 °C	-30...65 °C	-15...50 °C
Humidity	5...95 % r. h.	< 95 % r. h.	5...95 % r. h.
Dimensions/weight			
Dimensions	Refer to Dimensions [See page 16, 17]		
Weight	Refer to Dimensions [See page 16, 17]		
Flange connections	ISO 7005-2		
Pressure test points (P / T points)	G ¼ inch (connection) 2 mm x 40 mm (measuring tips)		

Application examples

PICVs in HVAC systems combined with variable speed pumps provide even higher energy efficiency. When sizing the pump, it must be made certain that the most critical branch or consumer in the system – usually the remotest from the pump – gets enough pressure (pump head). Thus, it is recommended to use a variable speed pump in constant-pressure mode with end-point feedback, to maintain a minimum differential pressure across the critical valve.

Residential buildings

Residential buildings with for example self-contained flat heating systems:

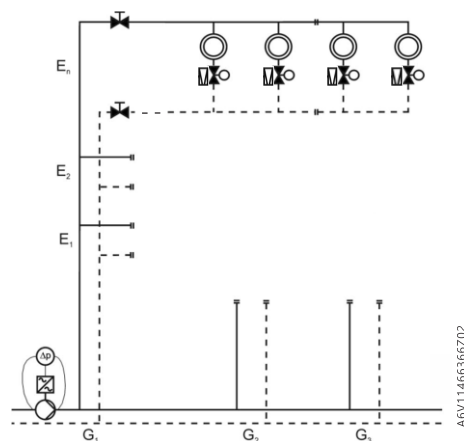

E = Floor
G = Group or zone
Non-residential buildings
Commercial buildings with for example Fan Coil Units or heat exchangers for heating or cooling:

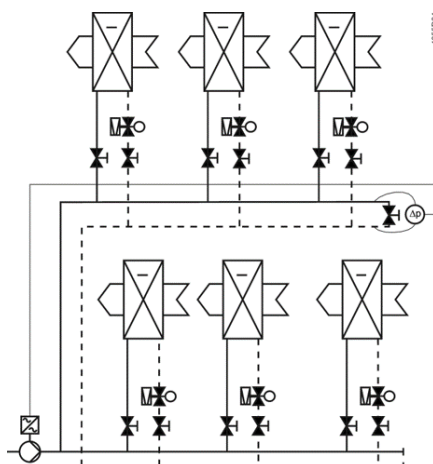

Dimensions

Dimensions in mm: VPF44..

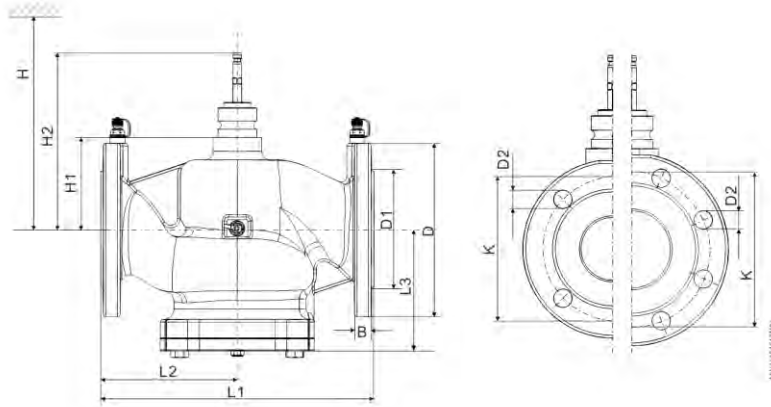

Product number	DN	B	ø D	ø D1	ø D2	L1	L2	L3	ø K	H1	H2	H			Weight	
												SAX..P	SAV..P	SQV..P		
	[mm]	[mm]	[mm]	[mm]	[mm]	[mm]	[mm]	[mm]	[mm]	[mm]	[mm]	[mm]	[mm]	[mm]	[mm]	kg
VPF44..	50	17	165	99	19 (4x)	230	115	115	125	102.5	199	545	-	492	15	
	65	17	185	118	19 (4x)	290	145	122	145	104	200.5	546.5	-	493.5	19	
	80	19	200	132	19 (8x)	310	155	139	160	104.5	201	546.5	-	493.5	28	

Note:

DN = Nominal size

H = Total actuator height plus minimum distance to the wall or the ceiling for mounting, connection, operation, maintenance etc.

H₁ = Dimension from the pipe center to install the actuator (upper edge).

H₂ = Valve in the OPEN position means that the valve stem is fully extended.

Dimensions in mm: VPF43..

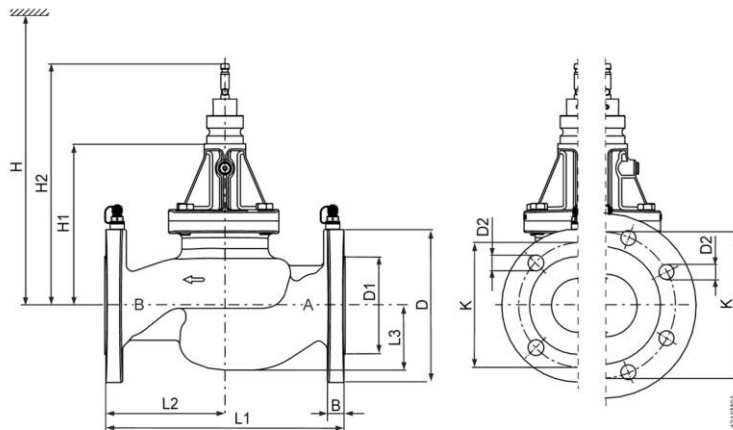

Product number	DN	B	ø D	ø D1	ø D2	L1	L2	L3	ø K	H1	H2	H			Weight	
												SAX..P	SAV..P	SQV..P		
	[mm]	[mm]	[mm]	[mm]	[mm]	[mm]	[mm]	[mm]	[mm]	[mm]	[mm]	[mm]	[mm]	[mm]	[mm]	kg
VPF43..	100	20	235	156	19 (8x)	350	162	111	180	332	449	-	800	720	50	
	125	25	270	184	19 (8x)	400	192	133	210	357	474	-	820	750	77	
	150	26	285	211	23 (8x)	480	230	156	240	401	521	-	870	790	111	
	200	28	380	266	23 (12x)	600	300	300	295	401	521	-	870	790	175	

Revision number overview

Product number	Valid from rev. no.	Product number	Valid from rev. no.
VPF44.50F15	..A	VPF44.50F25	..A
VPF44.65F25	..A	VPF44.65F35	..A
VPF44.80F35	..A	VPF44.80F45	..A
VPF43.100F70	..A	VPF43.100F90	..A
VPF43.125F110	..A	VPF43.125F135	..A
VPF43.150F160	..A	VPF43.150F200	..A
VPF43.200F210	..A	VPF43.200F280	..A

Documentation form

Installed location	Valve type	Actuator type	Valve size	Planned Presetting	Required Δp_{min} [kPa]	Verified Δp_{min} [kPa]	Flow ^{1) 2)} (m ³ /h)

1) Valid for VPF43/VPF44: Flow = If measured Δp_{min} (P1-P3) > Required Δp_{min} (P1-P3), then flow is as per presetting in datasheet, otherwise check system pressure.

2) Valid for VPF44 only: Please refer Kvs-table (provided separately).

По вопросам продаж и поддержки обращайтесь:

Алматы (7273)495-231
Ангарск (3955)60-70-56
Архангельск (8182)63-90-72
Астрахань (8512)99-46-04
Барнаул (3852)73-04-60
Белгород (4722)40-23-64
Благовещенск (4162)22-76-07
Брянск (4832)59-03-52
Владивосток (423)249-28-31
Владикавказ (8672)28-90-48
Владимир (4922)49-43-18
Волгоград (844)278-03-48
Вологда (8172)26-41-59
Воронеж (473)204-51-73
Екатеринбург (343)384-55-89
Иваново (4932)77-34-06
Ижевск (3412)26-03-58
Иркутск (395)279-98-46
Казань (843)206-01-48

Калининград (4012)72-03-81
Калуга (4842)92-23-67
Кемерово (3842)65-04-62
Киров (8332)68-02-04
Коломна (4966)23-41-49
Кострома (4942)77-07-48
Краснодар (861)203-40-90
Красноярск (391)204-63-61
Курган (3522)50-90-47
Курск (4712)77-13-04
Липецк (4742)52-20-81
Магнитогорск (3519)55-03-13
Москва (495)268-04-70
Мурманск (8152)59-64-93
Набережные Челны (8552)20-53-41
Нижний Новгород (831)429-08-12
Новокузнецк (3843)20-46-81
Новосибирск (383)227-86-73
Ноябрьск(3496)41-32-12

Омск (3812)21-46-40
Орел (4862)44-53-42
Оренбург (3532)37-68-04
Пенза (8412)22-31-16
Пермь (342)205-81-47
Петрозаводск (8142)55-98-37
Псков (8112)59-10-37
Ростов-на-Дону (863)308-18-15
Рязань (4912)46-61-64
Самара (846)206-03-16
Санкт-Петербург (812)309-46-40
Саранск (8342)22-96-24
Саратов (845)249-38-78
Севастополь (8692)22-31-93
Симферополь (3652)67-13-56
Смоленск (4812)29-41-54
Сочи (862)225-72-31
Ставрополь (8652)20-65-13
Сургут (3462)77-98-35

Сыктывкар (8212)25-95-17
Тамбов (4752)50-40-97
Тверь (4822)63-31-35
Тольятти (8482)63-91-07
Томск (3822)98-41-53
Тула (4872)33-79-87
Тюмень (3452)66-21-18
Улан-Удэ (3012)59-97-51
Ульяновск (8422)24-23-59
Уфа (347)229-48-12
Хабаровск (4212)92-98-04
Чебоксары (8352)28-53-07
Челябинск (351)202-03-61
Череповец (8202)49-02-64
Чита (3022)38-34-83
Якутск (4112)23-90-97
Ярославль (4852)69-52-93

Россия +7(495)268-04-70

Казахстан +7(7172)727-132

Киргизия +996(312)96-26-47

сайт: www.acvatix.nt-rt.ru || эл. почта: atv@nt-rt.ru