



SERIES 02

Three-port slipper valves PN10, female-threaded

VBI31...

Three-port slipper valves, PN10, female-threaded

- Grey cast iron EN-GJL-250
- DN 20...40
- k_{vs} 6.3...25 m³/h
- Angle of rotation 90°
- Female-threaded connections, Rp 3/4 ... Rp 1 1/2
- With manual adjuster
- Can be fitted with type SQK... or SQL... electromotoric actuators
- No maintenance required

Application

For use in closed-circuit heating systems, preferably in mixing applications.

Архангельск (8182)63-90-72
Астана +7(7172)727-132
Белгород (4722)40-23-64
Брянск (4832)59-03-52
Владивосток (423)249-28-31
Волгоград (844)278-03-48
Вологда (8172)26-41-59
Воронеж (473)204-51-73
Екатеринбург (343)384-55-89
Иваново (4932)77-34-06
Ижевск (3412)26-03-58
Казань (843)206-01-48

Калининград (4012)72-03-81
Калуга (4842)92-23-67
Кемерово (3842)65-04-62
Киров (8332)68-02-04
Краснодар (861)203-40-90
Красноярск (391)204-63-61
Курск (4712)77-13-04
Липецк (4742)52-20-81
Магнитогорск (3519)55-03-13
Москва (495)268-04-70
Мурманск (8152)59-64-93
Набережные Челны (8552)20-53-41

Нижний Новгород (831)429-08-12
Новокузнецк (3843)20-46-81
Новосибирск (383)227-86-73
Орел (4862)44-53-42
Оренбург (3532)37-68-04
Пенза (8412)22-31-16
Пермь (342)205-81-47
Ростов-на-Дону (863)308-18-15
Рязань (4912)46-61-64
Самара (846)206-03-16
Санкт-Петербург (812)309-46-40
Саратов (845)249-38-78

Смоленск (4812)29-41-54
Сочи (862)225-72-31
Ставрополь (8652)20-65-13
Тверь (4822)63-31-35
Томск (3822)98-41-53
Тула (4872)74-02-29
Тюмень (3452)66-21-18
Ульяновск (8422)24-23-59
Уфа (347)229-48-12
Челябинск (351)202-03-61
Череповец (8202)49-02-64
Ярославль (4852)69-52-93

Types

Type	Connection [Inch]	DN	k_{vs} [m ³ /h]	with actuators SQK... , SQL... Δp_{max} [kPa]
VBI31.20	Rp 3/4	20	6.3	30
VBI31.25	Rp 1	25	10	
VBI31.32	Rp 1 1/4	32	16	
VBI31.40	Rp 1 1/2	40	25	

DN = Nominal size

k_{vs} = Nominal flow rate of cold water (5...30 °C) through the fully open slipper valve by a differential pressure of 100 kPa (1 bar)

Δp_{max} = Maximum permissible differential pressure across the slipper valve's control path, valid for the entire actuating range of the motorised slipper valve

Accessories

Type	Description
ASK32 	The ASK32 mounting kit consists of a console and screw(s). For VBI31... Series 02. Mounting instructions are enclosed with the kit.

Ordering

The slipper valve, actuator and mounting kit, if required, must be ordered separately. When ordering, please specify the quantity, product name and type code.

Example: **1 3-port slipper valve type VBI31.25**
1 actuator type SQL33.00 and
1 mounting kit, type ASK32

Delivery

The slipper valve, actuator and mounting kit are packed separately.

Spare parts

See overview, section „Spare parts“, page 6

Equipment combinations

Type	Actuators		
	SQK34..., SQK84...	SQK33...	SQL33..., SQL83...
VBI31.20	direct mounting	ASK32	ASK32
VBI31.25			
VBI31.32			
VBI31.40			

Actuator overview

Type	Actuator type	Operating voltage	Positioning signal	Positioning time for 90°	Torque	Data-sheet
SQK33.00 ¹⁾	electro-motoric	AC 230 V	3-position	125 s	5 Nm	N4506
SQL33.00 ³⁾					12,5 Nm	
SQL33.03 ³⁾				30 s	10 Nm	
SQK34.00 ²⁾		AC 24 V		135 s	5 Nm	N4508
SQL83.00 ³⁾				125 s	12,5 Nm	N4506
SQK84.00 ²⁾				135 s	5 Nm	N4508

¹⁾ Can be fitted with 1 auxiliary switch, type ASC9.5

²⁾ Can be fitted with 1 auxiliary switch, type ASC9.7

³⁾ Can be fitted with 1 auxiliary switch type ASC9.5, or 1 double auxiliary switch, ASC9.4 or 1 potentiometer and 1 auxiliary switch type ASZ7.4.

Technical design / mechanical design

Application Boiler flow from the right or left. The manual adjuster, scale plate and slipper valve can be re-positioned to suit the application

Sizing

Flow diagram

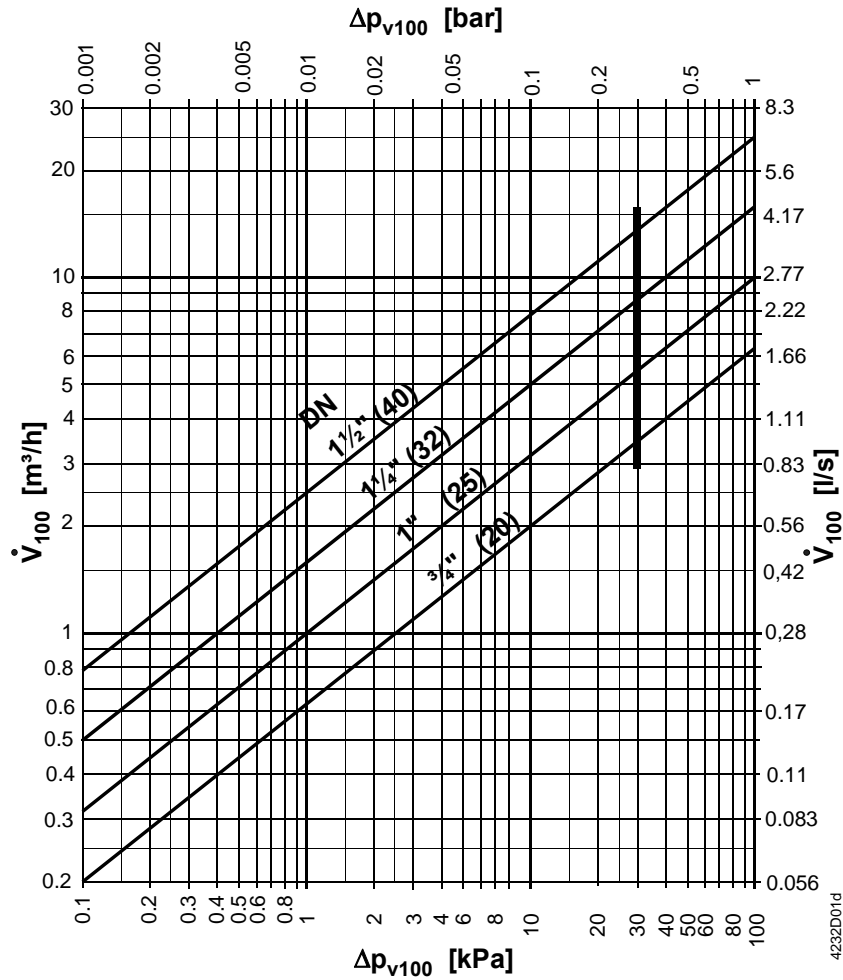

- Δp_{max} = Maximum permissible differential pressure across the slipper valve's control path, valid for the entire actuating range of the motorised slipper valve
- Δp_{v100} = Differential pressure across the fully open slipper valve by a volume flow V_{100}
- \dot{V}_{100} = Volumetric flow through the fully open slipper valve
- 100 kPa = 1 bar \approx 10 mWC
- 1 m³/h = 0.278 l/s water at 20 °C

4232D01d

Notes

Engineering

The VBI31... slipper valve should preferably be used in mixing applications. In systems where oxygen can enter the hydraulic system, there is an increased risk of corrosion which can cause the slipper valve to seize.

Mounting variants

Boiler flow from left

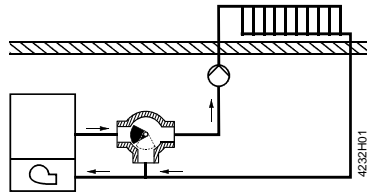

Factory setting

Boiler flow from right

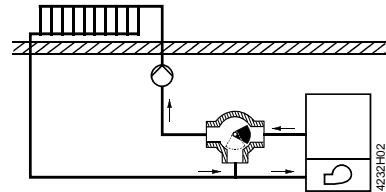

Re-position the valve slipper, scale plate and manual adjuster, as described in the mounting instructions for VB... slipper valves.

Mounting

The slipper valves are easy to assemble directly on site. The slipper valve, actuator and ASK32 mounting kit (if needed) are packed separately.

Accessory	Mounting instruction
ASK32	M4290.2 4 319 5597 0

Two special screws are provided in the housing cover to fix the ASK32 mounting kit and the scale plate for position indication.

Orientation

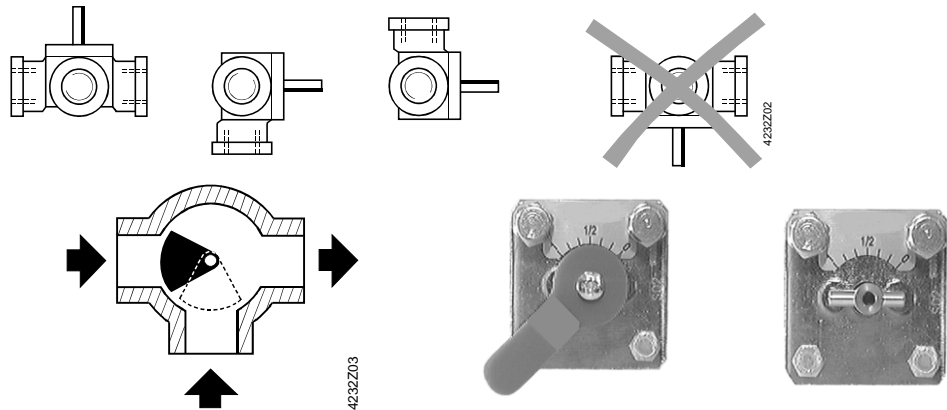

Factory setting
Slipper positioned for "boiler flow from left".

- Anti-clockwise rotation: opening
- Clockwise rotation: closing.

Manual adjuster with scale plate, position indicator and yellow colour marking for position of slipper
Position indicator at "0" = boiler flow path fully closed.

Commissioning

When commissioning the slipper valve, ensure that the position and rotation of the valve slipper are appropriate for the system concerned (see "Engineering").

The position of the valve slipper is indicated by:

- the manual adjuster and scale plate
- the yellow colour marking on the pin in the slipper valve shaft

Maintenance

Warning

Before performing any service work on the slipper valve, actuator or mounting kit:

- switch OFF the pump and power supply
- close the main shut-off valve in the pipework
- release pressure in the pipes and allow them to cool down completely.
- If necessary, disconnect electrical connections from terminals.

The slipper valve can be commissioned with the manual adjuster fitted, or with a correctly fitted actuator.

Disposal

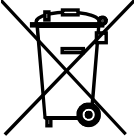

Before disposal the slipper valve must be dismantled and separated into its various constituent materials.

Legislation may demand special handling of certain components, or it may be sensible from an ecological point of view.

Current local legislation must be observed.

Warranty

The technical data given for these applications is valid only in conjunction with the Siemens actuators as detailed under «Equipment combinations».

All terms of the warranty will be invalidated by the use of actuators from other manufacturers.

Technical data

Functional data	PN class	PN 10 to ISO 7268
	Working pressure	max. 1000 kPa (10 bar) to ISO 7005 within the permissible medium temperature range
	Flow characteristic	through-port linear bypass linear
	Leakage rate	0...0,1 % of k_{vS} -value
	Permissible media	low temperature hot water, water with max 50 % vol. anti-freeze; Recommendation: water treatment to VDI 2035
	Medium temperature	1...120 °C
	Angle of rotation	90°
	Industry standards	Pressure Equipment Directive
Pressure Accessories		as per article 1, section 2.1.4
Fluid group 2		• without CE-marking as per article 3, section 3 (sound engineering practice)
Materials	Slipper valve body	Grey cast iron EN-GJL-250
	Shaft	stainless steel
	Slipper	Brass
	O-rings	EPDM
	Manual adjuster	Plastic
Dimensions / weight	Scale plate for position indication	Aluminum
	see «Dimensions»	
	Threaded connections	Rp... to ISO7-1

Dimensions

All dimensions in mm

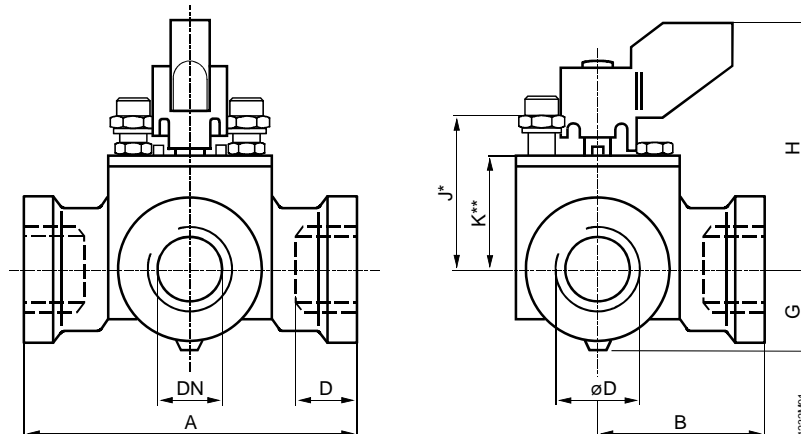

Type	DN	ø D [Inch]	A	B	D	G	H	J*	K**	Weight [kg]
VBI31.20	20	Rp ¾	110	55	14.5	24.5	74	46	34	1.4
VBI31.25	25	Rp 1			17					
VBI31.32	32	Rp 1¼	130	65	19	42.5	81.5	53.5	41.5	2.1
VBI31.40	40	Rp 1½								2.3

DN = Nominal size

ø D = Rp... threaded connections for pipes to ISO 7-1

J* = Installation height of actuator SQK34.00 or SQK84.00 without mounting kit

K** = Installation height of actuator SQK33.00, SQL33.0... or SQL83.00 with mounting kit ASK32

Overall height of slipper valve and actuator = Installation height of three-port slipper valve
 + Installation height of mounting kit, if used (ASK32 = 50 mm)
 + Installation height of actuator
 + Minimum clearance (>200 mm) from ceiling or wall for mounting, connection, operation, service etc.

Spare parts

Order number for spare parts

	O-Ring service set	manual adjuster
3-port slipper valve		
VBI31.20	4 67695230	7467601750
VBI31.25	4 67695230	7467601750
VBI31.32	4 67695230	7467601750
VBI31.40	4 67695230	7467601750

Mounting instructions for O-Ring replacement: M4241

Архангельск (8182)63-90-72
Астана +7(7172)727-132
Белгород (4722)40-23-64
Брянск (4832)59-03-52
Владивосток (423)249-28-31
Волгоград (844)278-03-48
Вологда (8172)26-41-59
Воронеж (473)204-51-73
Екатеринбург (343)384-55-89
Иваново (4932)77-34-06
Ижевск (3412)26-03-58
Казань (843)206-01-48

Калининград (4012)72-03-81
Калуга (4842)92-23-67
Кемерово (3842)65-04-62
Киров (8332)68-02-04
Краснодар (861)203-40-90
Красноярск (391)204-63-61
Курск (4712)77-13-04
Липецк (4742)52-20-81
Магнитогорск (3519)55-03-13
Москва (495)268-04-70
Мурманск (8152)59-64-93
Набережные Челны (8552)20-53-41

Нижний Новгород (831)429-08-12
Новокузнецк (3843)20-46-81
Новосибирск (383)227-86-73
Орел (4862)44-53-42
Оренбург (3532)37-68-04
Пенза (8412)22-31-16
Пермь (342)205-81-47
Ростов-на-Дону (863)308-18-15
Рязань (4912)46-61-64
Самара (846)206-03-16
Санкт-Петербург (812)309-46-40
Саратов (845)249-38-78

Смоленск (4812)29-41-54
Сочи (862)225-72-31
Ставрополь (8652)20-65-13
Тверь (4822)63-31-35
Томск (3822)98-41-53
Тула (4872)74-02-29
Тюмень (3452)66-21-18
Ульяновск (8422)24-23-59
Уфа (347)229-48-12
Челябинск (351)202-03-61
Череповец (8202)49-02-64
Ярославль (4852)69-52-93