

По вопросам продаж и поддержки обращайтесь:

Алматы (7273)495-231
Ангарск (3955)60-70-56
Архангельск (8182)63-90-72
Астрахань (8512)99-46-04
Барнаул (3852)73-04-60
Белгород (4722)40-23-64
Благовещенск (4162)22-76-07
Брянск (4832)59-03-52
Владивосток (423)249-28-31
Владикавказ (8672)28-90-48
Владимир (4922)49-43-18
Волгоград (844)278-03-48
Вологда (8172)26-41-59
Воронеж (473)204-51-73
Екатеринбург (343)384-55-89
Иваново (4932)77-34-06
Ижевск (3412)26-03-58
Иркутск (395)279-98-46
Казань (843)206-01-48

Калининград (4012)72-03-81
Калуга (4842)92-23-67
Кемерово (3842)65-04-62
Киров (8332)68-02-04
Коломна (4966)23-41-49
Кострома (4942)77-07-48
Краснодар (861)203-40-90
Красноярск (391)204-63-61
Курган (3522)50-90-47
Курск (4712)77-13-04
Липецк (4742)52-20-81
Магнитогорск (3519)55-03-13
Москва (495)268-04-70
Мурманск (8152)59-64-93
Набережные Челны (8552)20-53-41
Нижний Новгород (831)429-08-12
Новокузнецк (3843)20-46-81
Новосибирск (383)227-86-73
Ноябрьск(3496)41-32-12

Омск (3812)21-46-40
Орел (4862)44-53-42
Оренбург (3532)37-68-04
Пенза (8412)22-31-16
Пермь (342)205-81-47
Петрозаводск (8142)55-98-37
Псков (8112)59-10-37
Ростов-на-Дону (863)308-18-15
Рязань (4912)46-61-64
Самара (846)206-03-16
Санкт-Петербург (812)309-46-40
Саранск (8342)22-96-24
Саратов (845)249-38-78
Севастополь (8692)22-31-93
Симферополь (3652)67-13-56
Смоленск (4812)29-41-54
Сочи (862)225-72-31
Ставрополь (8652)20-65-13
Сургут (3462)77-98-35

Сыктывкар (8212)25-95-17
Тамбов (4752)50-40-97
Тверь (4822)63-31-35
Тольятти (8482)63-91-07
Томск (3822)98-41-53
Тула (4872)33-79-87
Тюмень (3452)66-21-18
Улан-Удэ (3012)59-97-51
Ульяновск (8422)24-23-59
Уфа (347)229-48-12
Хабаровск (4212)92-98-04
Чебоксары (8352)28-53-07
Челябинск (351)202-03-61
Череповец (8202)49-02-64
Чита (3022)38-34-83
Якутск (4112)23-90-97
Ярославль (4852)69-52-93

Россия +7(495)268-04-70

Казахстан +7(7172)727-132

Киргизия +996(312)96-26-47

сайт: www.acvatix.nt-rt.ru || эл. почта: atv@nt-rt.ru

ТЕХНИЧЕСКИЕ ХАРАКТЕРИСТИКИ НА ШАРОВЫЕ КРАНЫ

ACVATIX™

2-port shutoff valves changeover ball valves, PN 40, with externally threaded connection

VAG60..



For use in heating, ventilation, and air conditioning plants as shutoff or changeover ball valve. In closed circuits.

- Ball valve body made of brass CW602N (DZR)
- DN 15...50
- K_{vs} 8...96 m³/h
- Flat sealing, externally threaded connections G..B, as per ISO 228-1
- Fitting sets ALG.. with threaded connection
- Rotational angle 90°
- Can be combined with electromotoric rotary actuators GQD..9A, GMA..9E with spring return and GSD..9A, GDB..9E, GLB..9E without spring return
- For applications with auxiliary functions (e.g. auxiliary switches, potentiometers, standard rotary actuators from the DAC product range can also be combined)

Features

- **Moderately priced:**
Optimized flow rates mean smaller ball valves can be selected. Low torque means you can combine them with small, less expensive rotary actuators.
- **Long life expectancy:**
Maintenance-free construction, also thanks to low friction stem and polished ball made of chrome-plated DZR brass.
- **Simple mounting:**
The brackets, pre-mounted on the actuators, means you can mount them on the ball valves without tools.

Technical design

Design

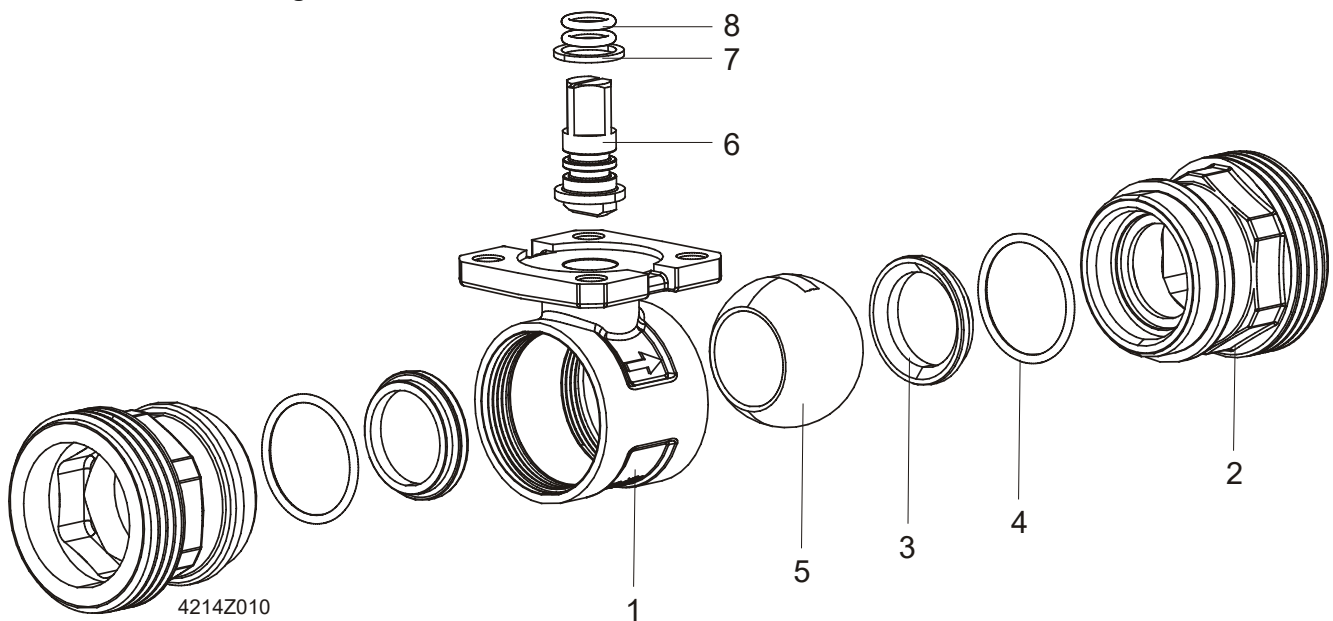

1 Housing

3 Seat

5 Marble

7 Slide clutch

2 Connection with external threading

4 O-ring seal

6 Stem, squared

8 O-ring seal

Sizing

Flow diagram:

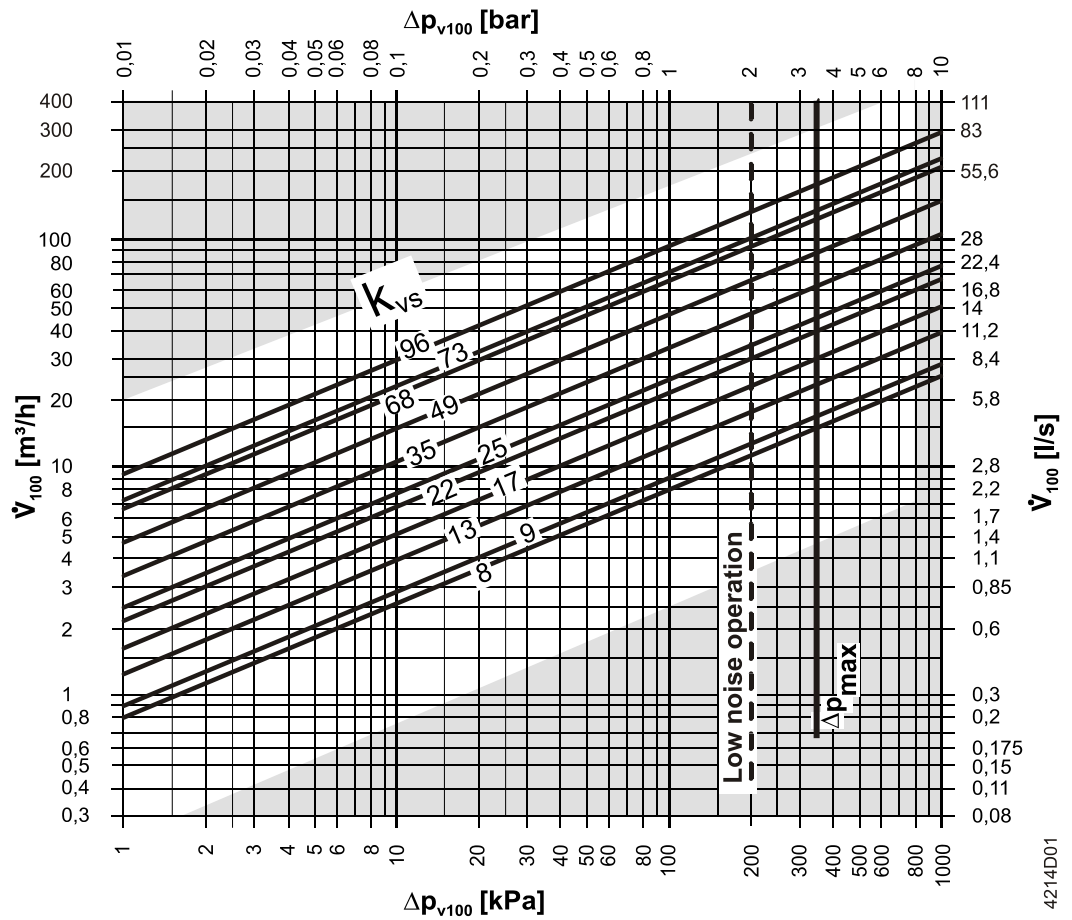

-- Δp_{max} for VAG60.. and VBG60.., for details, see table on equipment combinations

Δp_{max} = Maximum permissible differential pressure over the ball valve, valid for the entire positioning range of the ball valve rotary actuator unit; if low noise operation is desired, we recommend a maximum permissible differential pressure of 200 kPa

Δp_{v100} = Differential pressure over the fully opened ball valve and over the control path at a volume flow \dot{V}_{100}

\dot{V}_{100} = Volume flow through the fully opened ball valve

100 kPa = 1 bar \approx 10 mWS

1 m^3/h = 0.278 l/s water at 20 °C

4214D01

Cavitation

Cavitation increases wear and tear of the ball and seat and results in unwanted noise. Cavitation can be prevented by not exceeding the differential pressures as per the flow diagram and maintaining the static pressures depicted below.

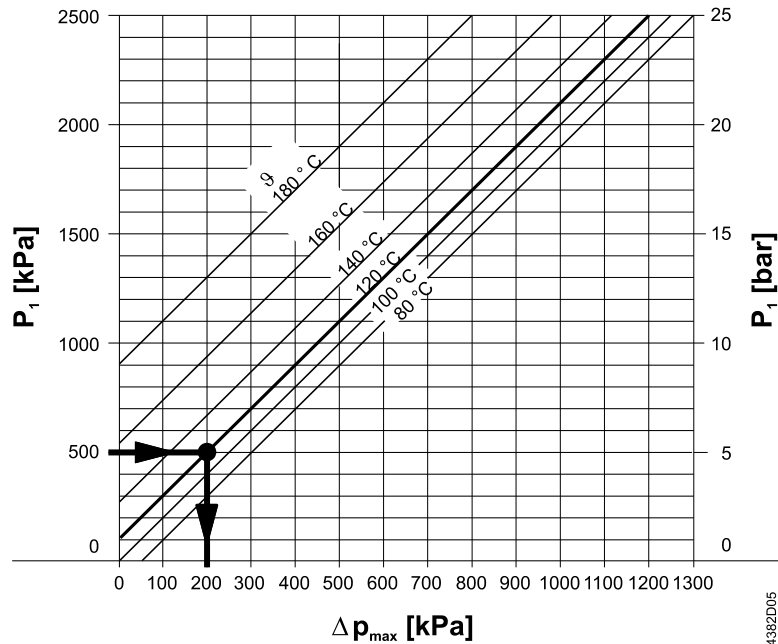

- Δp_{\max} = Differential pressure at a nearly closed ball valve to largely avoid cavitation
- p_1 = Static pressure at the ball valve inlet
- P_3 = Static pressure at the ball valve outlet
- M = Pump
- J = Water temperature

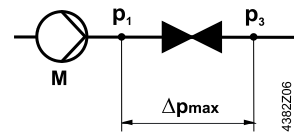

Example with hot water:

Pressure p_1 at ball valve inlet: 500 kPa (5 bar)

Water temperature: 120 °C

The above diagram clearly indicates that the maximum permissible differential pressure is $\Delta p_{\max} \rightarrow 200$ kPa (2 bar) at a nearly closed ball valve.

Note on chilled water applications:

UTo prevent cavitation in chilled water circuits, sufficient counter pressure must be supplied to the ball valve outlet, e.g. using an additional butterfly valve downstream of the ball valve. Maximum permissible differential pressure over the ball valve: See 80 °C curve in the above diagram.

Operating pressure and operating temperature

Liquids:

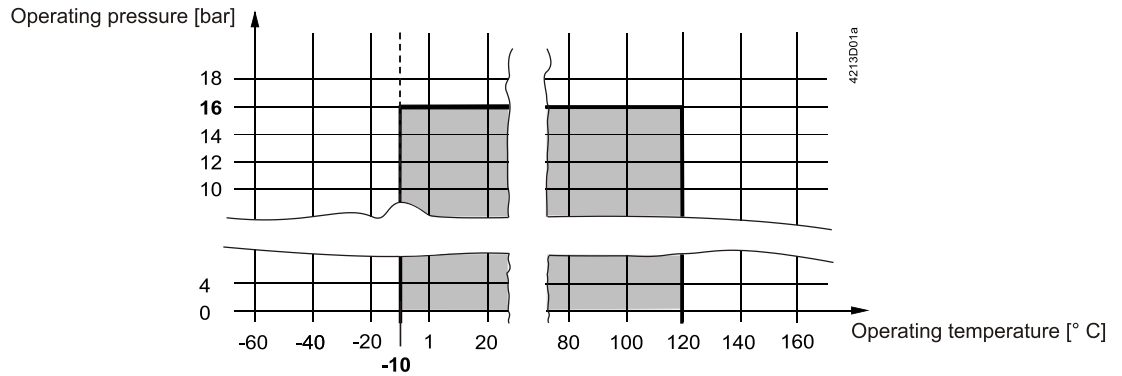

Operating pressure and medium temperature per ISO 7005

(Observe all local and applicable laws).

Type summary

Type				DN	k _{vs}
Shut-off ball valve 2-port	Stock number	Change-over ball valve 3-port	Stock number		
-	-	VBG60.15-8T	S55230-V136	15	8 ¹⁾
VAG60.15-9	S55230-V130	-	-		9
-	-	VBG60.20-13T	S55230-V137	20	13 ¹⁾
VAG60.20-17	S55230-V131	-	-		17
-	-	VBG60.25-13T	S55230-V138	25	13 ¹⁾
VAG60.25-22	S55230-V132	-	-		22
-	-	VBG60.32-25T	S55230-V139	32	25 ¹⁾
VAG60.32-35	S55230-V133	-	-		35
-	-	VBG60.40-49T	S55230-V140	40	49 ¹⁾
VAG60.40-68	S55230-V134	-	-		68
-	-	VBG60.50-73T	S55230-V141	50	73 ¹⁾
VAG60.50-96	S55230-V135	-	-		96

¹⁾ k_{vs} Bypass B > 50 % of k_{vs} A – AB

DN = Nominal size

k_{vs} = Flow nominal value for chilled water (5...30 °C) through a fully opened ball valve at a differential pressure of 100 kPa (1 bar)

Fittings

Type	Stock number	Description
ALG..2	BPZALG..2	2 piece fittings set for 2-port valves, existing of 2 cap nuts, 2 insert nuts, and 2 flat seals ALG..2B are fittings made of brass for media temperatures up to 100 °C
ALG..2B	S55846-Z1..	
ALG..3	BPZ:ALG..3	3 piece fittings set for 3-port valves, existing of 3 cap nuts, 3 insert nuts, and 3 flat seals. ALG..3B are fittings made of brass for media temperatures up to 100 °C
ALG..3B	S55846-Z1..	

Insulation shells

Insulation shells are available for heating/cooling insulation as a separate accessory:

Type	Material	Density	Thermal conductivity at tm 40 °C	Operating temperature
ALI..V..G..	Polyethylene foam	29 kg/m ³	0.0372 W/mK	-10...100 °C

Ball valve	Insulation shell	Stock number
VAG60.15..	ALI15VAG60/61	S55845-Z162
VAG60.20..	ALI20VAG60/61	S55845-Z163
VAG60.25..	ALI25VAG60/61	S55845-Z164
VAG60.32..	ALI32VAG60/61	S55845-Z165
VAG60.40..	ALI40VAG60/61	S55845-Z166
VAG60.50..	ALI50VAG60/61	S55845-Z167
VBG60.15..	ALI15VBG60/61	S55845-Z168
VBG60.20..	ALI20VBG60/61	S55845-Z169
VBG60.25..	ALI25VBG60/61	S55845-Z170
VBG60.32..	ALI32VBG60/61	S55845-Z171
VBG60.40..	ALI40VBG60/61	S55845-Z172
VBG60.50..	ALI50VBG60/61	S55845-Z173

Insulation shells for shut-off and change-over ball valves

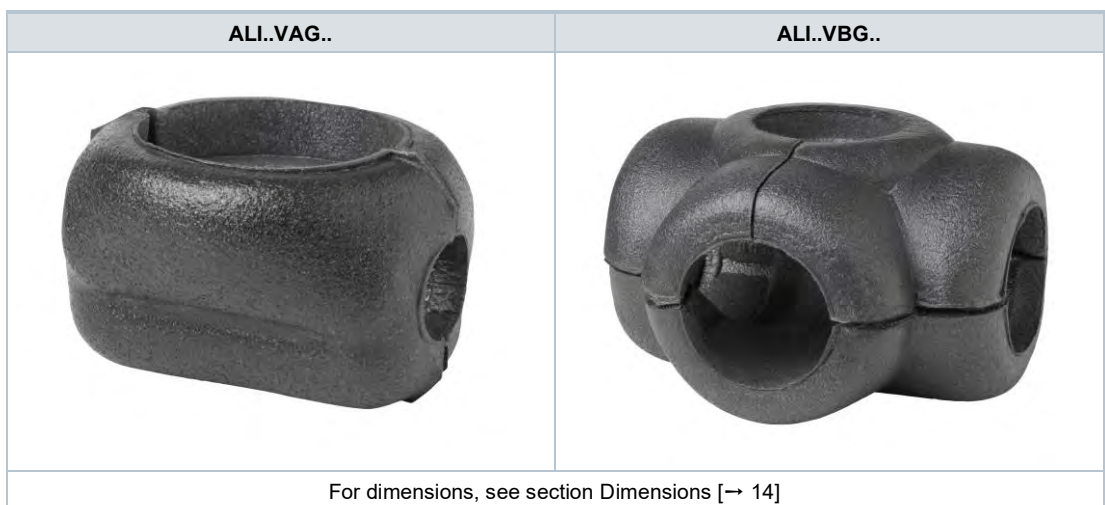

Filter

Installed upstream of ball valve:

Type	Stock number	Description	DN	Mesh width [mm]
ALX15	S55845-Z174	Filter with internal threading	15	0.5
ALX20	S55845-Z175		20	0.8
ALX25	S55845-Z176		25	
ALX32	S55845-Z177		32	
ALX40	S55845-Z178		40	
ALX50	S55845-Z179		50	

Equipment combinations

Type	Rotary actuators									
	GSD..9A		GQD..9A		GDB..9E		GMA..9E		GLB..9E	
	Δp_{max}	Δp_s	Δp_{max}	Δp_s	Δp_{max}	Δp_s	Δp_{max}	Δp_s	Δp_{max}	Δp_s
	[kPa]									
VAG60.15-9	350	1400	350	1400	350	1400	350	1400	350	1400
VAG60.20-17										
VAG60.25-22										
VAG60.32-35	-	-	-	-	-	-	-	1000		1000
VAG60.40-68								800		800
VAG60.50-96								600		600
VBG60.15-8T	350	-	350	-	350	-	350	-	350	-
VBG60.20-13T										
VBG60.25-13T										
VBG60.32-25T	-	-	-	-	-	-	-	-	-	-
VBG60.40-49T										
VBG60.50-73T										

Δp_{max} = Maximum permissible differential pressure over the ball valve control path, valid for the entire positioning range of the ball valve rotary actuator unit; if low noise operation is desired, we recommend a differential pressure of ≤ 200 kPa

Δp_s = Maximum permissible differential pressure (closing pressure) at which the ball valve rotary actuator unit securely closes against the pressure

Overview of rotary actuators for ball valves

Type ¹⁾	Operating voltage	Positioning		Spring return		Data sheet
		Signal	Time	Function	Time	
GSD141.9A	AC/DC 24 V	Open-close ²⁾	30 s	-	-	N4655
GSD341.9A	AC 230 V					
GQD121.9A	AC/DC 24 V	2-position	30/15 s ³⁾	Yes	15 s	N4659
GQD321.9A	AC 230 V					
GMA121.9E	AC/DC 24 V		90/15 s ³⁾			N4658
GMA321.9E	AC 230 V					
GDB141.9E	AC/DC 24 V	2- or 3-position	150 s	-	-	A6V10636150
GDB341.9E	AC 100-240 V	(2) 3-position				N4657
GLB131.9E ⁴⁾	AC 24 V					
GLB331.9E ⁴⁾	AC 230 V					
GLB141.9E	AC/DC 24 V	2- or 3-position				A6V10636203
GLB341.9E	AC 100...240 V					

¹⁾ Actuator type: electromotoric

²⁾ 2-wire SPDT (single pole double throw)

³⁾ open / close

⁴⁾ While stock lasts

Ordering

Please indicate material, article type, order text, and quantity; example:

Material	Article type	Order text	Quantity
VAG60.25-22	VAG60.25-22	Open/close ball valve, externally threaded, 2-port	2
GLB131.9E	GLB131.9E	Electromotoric rotary actuator without spring return for ball valves	2

Delivery

Ball valves, rotary actuators, and mounting kits are not assembled and are delivered in individual packaging.

Applications with auxiliary functions

A standard actuator with corresponding functionality can be used if a ball valve application requires a rotary actuator with auxiliary functions (e.g. auxiliary switch or potentiometer). In this case, mounting kit ASK77.. is required in **addition** to the rotary actuator.

Follow the mounting instructions when mounting.

Rotary actuator	Options	Order text mounting kit
GMA..1E (with spring return)	Potentiometer, auxiliary switch	ASK77.2 Accessory Kit BV for GMA..1.9E
GDB..1E (without spring return)		ASK77.3 Accessory Kit BV for GDB..1.9E
GLB..1E (without spring return)		ASK77.3 Accessory Kit BV for GLB..1.9E
GQD..1A (with spring return)	Auxiliary switch	ASK77.5 Accessory Kit BV for GQD..1.9A
GSD..1A ¹⁾ (without spring return)		ASK77.5 Accessory Kit BV for GSD..1.9A

¹⁾ GSD..4..1A are not compatible with ball valves.

Product documentation

Title	Content	Document ID
Mounting instructions Ball valve VAG60..., VBG60..T	Mounting instructions	M4214 (74 319 0923 0)
Rotary actuators for ball valves GSD..41.9A	Data sheet: product description	N4655
Rotary actuators for ball valves GQD..9A	Data sheet: product description	N4659
Rotary actuators for ball valves GMA..9E	Data sheet: product description	N4658
Rotary actuators for ball valves GDB..9E	Data sheet: product description	A6V10636150
Rotary actuators for ball valves GDB..9E, GLB..9E	Data sheet: product description	N4657
Rotary actuators for ball valves GLB..9E	Data sheet: product description	A6V10636203
Mounting instructions Mounting kit ASK77.2, ASK77.3	Mounting instructions	M4696 (74 319 0648 0)
Mounting instructions Mounting kit ASK77.5	Mounting instructions	A6V11171911 (A5W00032790)

Safety

	⚠ DANGER
	<p>There is a risk to operating personnel and device when working on the unit Failure to comply with these safety notes can result in personal injury and damage to property from pipe pressure, electrical voltage, or device in operation.</p> <p>▷ Note the following when servicing a ball valve/rotary actuator:</p> <ul style="list-style-type: none"> • Switch off both pump and operating voltage. • Close shutoff valves. • Release pressure in the pipes and allow them to cool down completely. • Disconnect electrical connections from the terminals as needed. • The rotary actuator must be properly installed prior to recommissioning the ball valve.

	⚠ CAUTION
	<p>National safety regulations Failure to comply with national safety regulations may result in personal injury and property damage.</p> <ul style="list-style-type: none"> • Observe national provisions and comply with the appropriate safety regulations.

Engineering

We recommend installing the ball valve with spring return since temperatures are lower on heating plants which increases the lifespan of the sealing gland on the stem.

Ensure there is no cavitation (see section Technical design [→ 2]).

A filter must be installed upstream of the ball valve to increase functional safety.

Permissible media

Using the ball valve in combination with potassium formate-based media, such as Hycool or Temper, can result in leakage over the stem to the outside. The reason is the high level of penetration at low surface tension of media based on potassium formate.

Siemens rejects any and all liability for damages or consequential damages resulting from the use of this media in combination with our ball valves.

Mounting

It is easy to assemble the ball valve and rotary actuator; it can be done at the construction site. No special tools or settings required.

Ball valve VAG60.. / VBG60.. is supplied together with mounting instructions M4214 (74 319 0923 0).

Mounting position

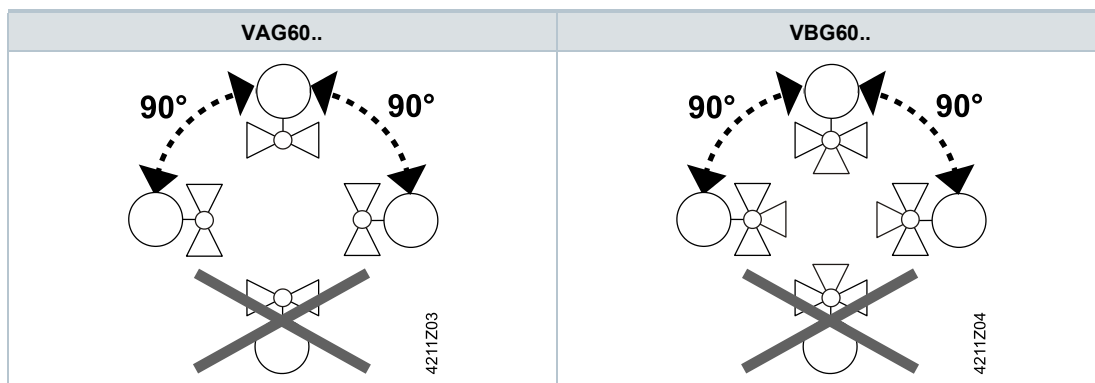

Pipe connection

Avoid leakage:

- Install fittings as per ISO 7-1. Ball valves (internal threading) = „Rp“; Piping (external threading) = „R“.
- Do not use too much hemp or PTFE tape.
- Do not tighten pipe threading to the very end.
- Place the pliers/wrench on the ball valve union nut that is closer to the pipe to be tightened or loosened.

Flow direction

Make sure that the valve is mounted in the proper flow direction. A symbol is applied to the ball valve body:

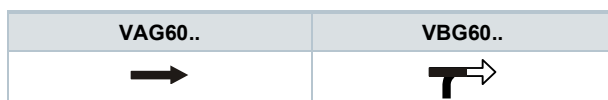

Ball valve	Laser marking	Position as delivered	90 ° turned (clockwise)
VAG60.. 2-port shut-off ball valve	-	<p style="text-align: center;">A – AB = 100 %</p>	<p style="text-align: center;">A – AB = 0 %</p>
VBG60..T 3-port change-over ball valve, T-shaped		<p style="text-align: center;">A – AB = 100 % B – AB = 0 %</p>	<p style="text-align: center;">A – AB = 0 % B – AB = 100 %</p>

Maintenance

Ball valves VAG60.. and VBG60.. are maintenance free.

Disposal

The valve should not be disposed of as domestic garbage.

- Special treatment for individual components may be required by law or make ecological sense.
- Comply with all local and currently applicable laws and regulations.

Warranty

Technical data on specific applications are valid only together with Siemens products listed under "Equipment combinations". Siemens rejects any and all warranties in the event that third-party products are used.

Technical data

Functional data		
	VAG60..	VBG60..
PN class	PN 40 per ISO 7268	
Operating pressure	per ISO 7005 within the permissible media temperature as per section Technical design [→ 2]	
Leakage through-port	Water proof per EN 60534-4 L/1, improved class 5	Water proof per EN 60534-4 L/1, improved class 4
Leakage bypass	-	< 1 %
Permissible media	Chilled water, low temperature hot water, hot water, water with antifreeze. Recommendation: Water treatment per VDI 2035 Note: section Engineering [→ 10]	
Medium temperature	-10...120 °C	
Rotational angle	90 °	

Materials	
Ball valve body	Dezincification-resistant hot-pressed brass (DZR ¹⁾), CW602N
Marble	Dezincification-resistant hot-pressed brass (DZR ¹⁾), CW602N, chrome plated
Stem	Dezincification-resistant hot-pressed brass (DZR ¹⁾), CW602N
Sealing gland	EPDM O-rings

Dimensions / Weight	
See section Dimensions [→ 14]	
Connections with external threading	G..B per ISO 228-1

Standards, directives and approvals	
Pressure Equipment Directive	DGR 2014/68/EU
Pressure accessories	Range: Article 1, para. 1 Definition: Article 2, para. 5
Fluid group 2	Without CE certification as per article 3, para. 3 (generally applicable engineering practice) ²⁾
EAC compliance	Eurasien compliance
Environmental compatibility	Environmental Declaration CE1E4214en ³⁾ contains data on environmental-compatible product design and assessment (RoHS compliance, compositions, packaging, environmental benefits and disposal).

¹⁾ Dezincification resistant

²⁾ Fittings for a product where PS x DN < 1000 do not require special testing and cannot have CE labeling.

³⁾ See section Product documentation [→ 9]

VAG60..

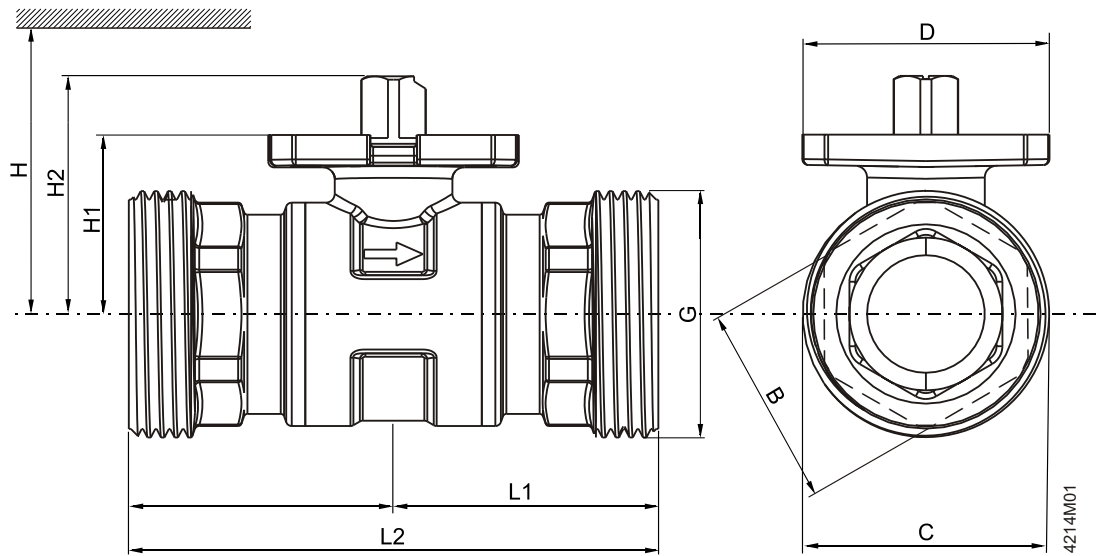

- DN = Nominal size
- H = Total height of actuator plus minimum mounting distance to wall or ceiling, for mounting, connection, operation, maintenance, etc.
- H1 = Dimension from the pipe to the center to install actuator (upper edge)

Type	DN	B	C	D	G	L1	L2	H1	H2
VAG60.15-9	15	27	33	42	G 1 B	43.5	87	27.6	37.6
VAG60.20-17	20	35	42		G 1 ¼ B	44.7	89.4	30.5	40.5
VAG60.25-22	25		48		G 1 ½ B	44.7			
VAG60.32-35	32	38	59.7		G 2 B	50.1	100.2	34.3	44.3
VAG60.40-68	40	49	65.7		G 2 ¼ B	58.3	116.6	39.8	49.8
VAG60.50-96	50	61	81.6		G 2 ¾ B	62	124	52.8	62.8

Type	H					Weight
	GSD..9A	GQD..9A	GDB..9E	GMA..9E	GLB..9E	
	mm					kg
VAG60.15-9	> 300	> 300	> 300	> 300	> 300	0.36
VAG60.20-17						0.55
VAG60.25-22	> 320	> 320	> 320	> 320	> 320	0.57
VAG60.32-35	-	-	-			0.84
VAG60.40-68						1.29
VAG60.50-96				> 335	> 335	1.98

VBG60..T

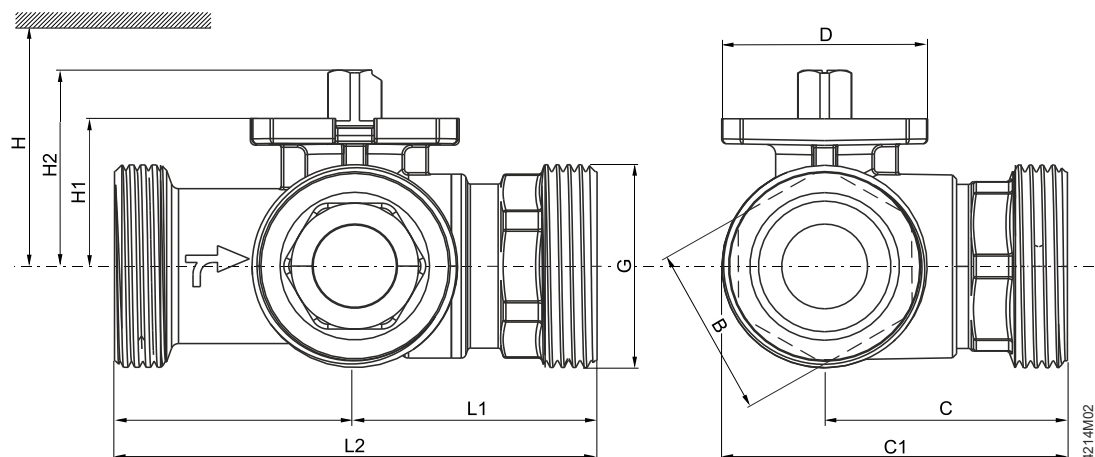

DN = Nominal size

H = Total height of actuator plus minimum mounting distance to wall or ceiling, for mounting, connection, operation, maintenance, etc.

H1 = Dimension from the pipe to the center to install actuator (upper edge)

Type	DN	B	C	C1	D	G	L1	L2	H1	H2
		mm				Inch	mm			
VBG60.15-8T	15	27	44.4	61	42	G 1 B	44.3	88.6	27.6	37.6
VBG60.20-13T	20	35	49.5	70		G 1 ¼ B	49	98	30.5	40.5
VBG60.25-13T	25			73		G 1 ½ B	49.2	98.4		
VBG60.32-25T	32	38	63.7	94		G 2 B	57	114	34.3	44.3
VBG60.40-49T	40	49	74.3	107		G 2 ¼ B	63.8	127.6	39.8	49.8
VBG60.50-73T	50	61	82.3	123		G 2 ¾ B	69	138	52.8	62.8

Type	H					Weight
	GSD..9A	GQD..9A	GDB..9E	GMA..9E	GLB..9E	
	mm					kg
VBG60.15-8T	> 300	> 300	> 300	> 300	> 300	0.45
VBG60.20-13T						0.68
VBG60.25-13T	> 320	> 320	> 320	> 320	> 320	0.75
VBG60.32-25T	-	-	-			1.2
VBG60.40-49T						1.84
VBG60.50-73T	> 335	> 335	> 335	> 335	> 335	2.83

Fittings

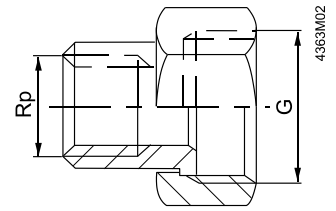

For 2-port valves VAG60.. (2 piece set)		For 3-port valves VBG60.. (3 piece set)		Valve type	G	Rp
Type	Stock number	Type	Stock number		Inch	
ALG152	S55846-Z100	ALG153	S55846-Z101	V..G60.15	G 1 B	Rp ½
ALG202	S55846-Z102	ALG203	S55846-Z103	V..G60.20	G 1¼ B	Rp ¾
ALG252	S55846-Z104	ALG253	S55846-Z105	V..G60.25	G 1½ B	Rp 1
ALG322	S55846-Z106	ALG323	S55846-Z107	V..G60.32	G 2 B	Rp 1¼
ALG402	S55846-Z108	ALG403	S55846-Z109	V..G60.40	G 2¼ B	Rp 1½
ALG502	S55846-Z110	ALG503	S55846-Z111	V..G60.50	G 2¾ B	Rp 2

- Valve side with cylindrical threading per ISO 228-1
- Pipe side with cylindrical threading per ISO 7-1
- ALG..B fittings up to 100 °C medium temperature

Insulation shells for 2-port control ball valves (VAG60..)

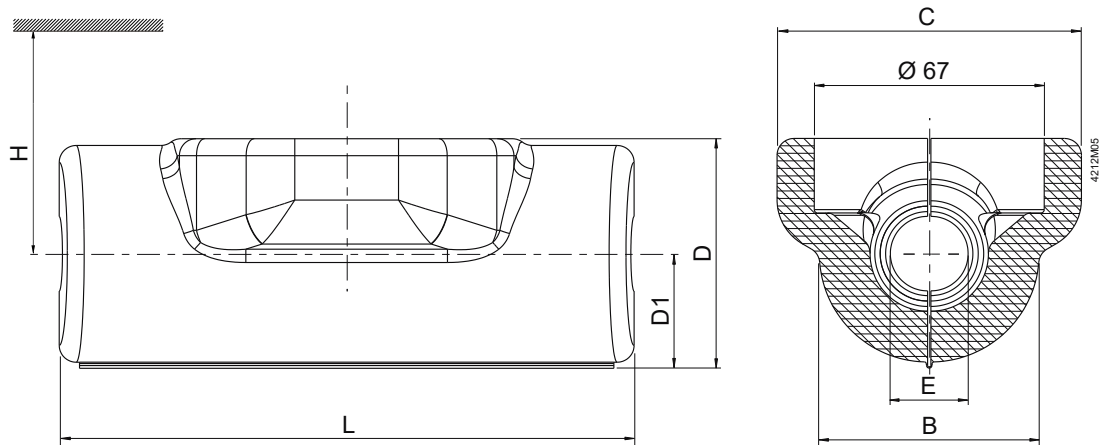

DN = Nominal size

H = Total height of actuator plus minimum mounting distance to wall or ceiling, for mounting, connection, operation, maintenance, etc.

Type		DN	B	C	D	D1	E	L
Insulation shell	For ball valve							
ALI15VAG60/61	VAG60.15..	15	64	92	66	32	21	170
ALI20VAG60/61	VAG60.20..	20	80	88	88	42	27	
ALI25VAG60/61	VAG60.25..	25	90	95	100	48	34	185
ALI32VAG60/61	VAG60.32..	32	102	100	108	54	43	
ALI40VAG60/61	VAG60.40..	40	118	105	124	60	48	215
ALI50VAG60/61	VAG60.50..	50	130	110	134	66	61	225

Type		H					Weight
Insulation shell	For ball valve	GSD..9A	GQD..9A	GDB..9E	GMA..9E	GLB..9E	
		mm					g
ALI15VAG60/61	VAG60.15..	> 300	> 300	> 300	> 300	> 300	24
ALI20VAG60/61	VAG60.20..						30
ALI25VAG60/61	VAG60.25..	> 320	> 320	> 320	> 320	> 320	32
ALI32VAG60/61	VAG60.32..	-	-	-			40
ALI40VAG60/61	VAG60.40..				52		
ALI50VAG60/61	VAG60.50..				> 335	> 335	59

Insulation shells for 3-port control ball valves (VBG60..)

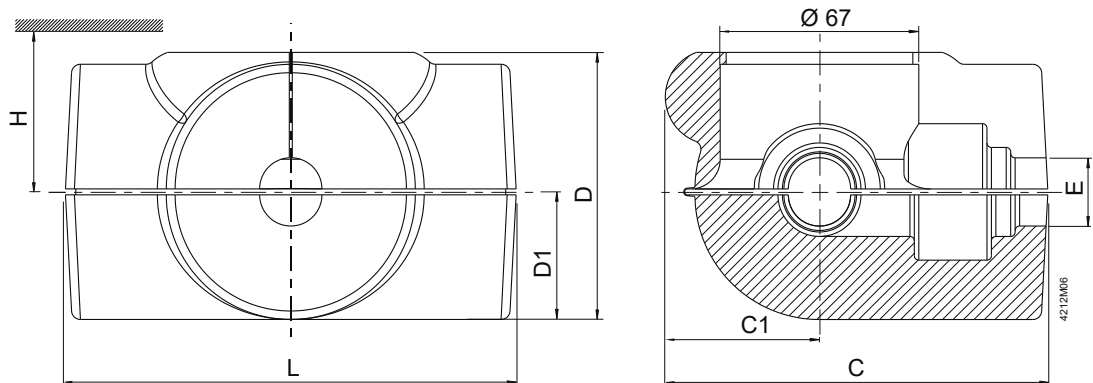

DN = Nominal size

H = Total height of actuator plus minimum mounting distance to wall or ceiling, for mounting, connection, operation, maintenance, etc.

Type		DN	C	C1	D	D1	E	L
Insulation shell	For ball valve							
		mm						
ALI15VBG60/61	VBG60.15..	15	132	50	87	42	21	155
ALI20VBG60/61	VBG60.20..	20	135	58	97	49	27	170
ALI25VBG60/61	VBG60.25..	25	145	51	104	51	34	185
ALI32VBG60/61	VBG60.32..	32	175	61	124	60	43	210
ALI40VBG60/61	VBG60.40..	40	185		130	63	48	225
ALI50VBG60/61	VBG60.50..	50	195	65	138	67	61	235

Type		H					Weight
Insulation shell	For ball valve	GSD..9A	GQD..9A	GDB..9E	GMA..9E	GLB..9E	
		mm					g
ALI15VAG60/61	VAG60.15..	> 300	> 300	> 300	> 300	> 300	45
ALI20VAG60/61	VAG60.20..						55
ALI25VAG60/61	VAG60.25..	> 320	> 320	> 320	> 320	> 320	65
ALI32VAG60/61	VAG60.32..	-	-	-			88
ALI40VAG60/61	VAG60.40..				105		
ALI50VAG60/61	VAG60.50..				> 335	> 335	115

Filter

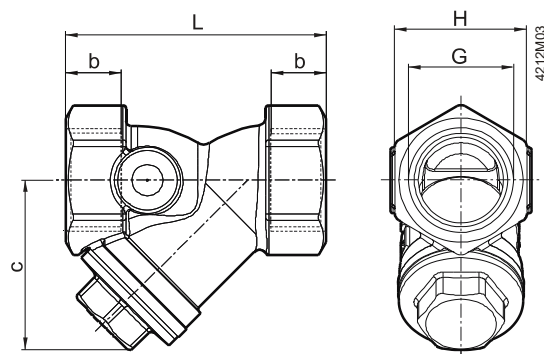

Type	DN	b	c	G	L	H	k _{vs}	Weight
		mm		Zoll ¹⁾	mm			kg
ALX15	15	12	38	G ½	54	27	3.5	0.178
ALX20	20	15	43	G ¾	67	34	5.8	0.290
ALX25	25	16	53	G 1	79	41	9.1	0.410
ALX32	31	17	64	G 1¼	98	51	19	0.680
ALX40	40	18	70	G 1½	106	57	24	0.874
ALX50	50	20	85	G 2	122	69	36	1.428

¹⁾ ISO 228-1

Revision numbers

Type	Valid from rev. no.	Type	Valid from rev. no.
Shutoff ball valve VAG60..		Changeover ball valve VBG60..T	
2-port		3-port	
VAG60.15-9	..A	VBG60.15-8T	..A
VAG60.20-17	..A	VBG60.20-13T	..A
VAG60.25-22	..A	VBG60.25-13T	..A
VAG60.32-35	..A	VBG60.32-25T	..A
VAG60.40-68	..A	VBG60.40-49T	..A
VAG60.50-96	..A	VBG60.50-73T	..A

По вопросам продаж и поддержки обращайтесь:

Алматы (7273)495-231
 Ангарск (3955)60-70-56
 Архангельск (8182)63-90-72
 Астрахань (8512)99-46-04
 Барнаул (3852)73-04-60
 Белгород (4722)40-23-64
 Благовещенск (4162)22-76-07
 Брянск (4832)59-03-52
 Владивосток (423)249-28-31
 Владикавказ (8672)28-90-48
 Владимир (4922)49-43-18
 Волгоград (844)278-03-48
 Вологда (8172)26-41-59
 Воронеж (473)204-51-73
 Екатеринбург (343)384-55-89
 Иваново (4932)77-34-06
 Ижевск (3412)26-03-58
 Иркутск (395)279-98-46
 Казань (843)206-01-48

Калининград (4012)72-03-81
 Калуга (4842)92-23-67
 Кемерово (3842)65-04-62
 Киров (8332)68-02-04
 Коломна (4966)23-41-49
 Кострома (4942)77-07-48
 Краснодар (861)203-40-90
 Красноярск (391)204-63-61
 Курган (3522)50-90-47
 Курск (4712)77-13-04
 Липецк (4742)52-20-81
 Магнитогорск (3519)55-03-13
 Москва (495)268-04-70
 Мурманск (8152)59-64-93
 Набережные Челны (8552)20-53-41
 Нижний Новгород (831)429-08-12
 Новокузнецк (3843)20-46-81
 Новосибирск (383)227-86-73
 Ноябрьск (3496)41-32-12

Омск (3812)21-46-40
 Орел (4862)44-53-42
 Оренбург (3532)37-68-04
 Пенза (8412)22-31-16
 Пермь (342)205-81-47
 Петрозаводск (8142)55-98-37
 Псков (8112)59-10-37
 Ростов-на-Дону (863)308-18-15
 Рязань (4912)46-61-64
 Самара (846)206-03-16
 Санкт-Петербург (812)309-46-40
 Саранск (8342)22-96-24
 Саратов (845)249-38-78
 Севастополь (8692)22-31-93
 Симферополь (3652)67-13-56
 Смоленск (4812)29-41-54
 Сочи (862)225-72-31
 Ставрополь (8652)20-65-13
 Сургут (3462)77-98-35

Сыктывкар (8212)25-95-17
 Тамбов (4752)50-40-97
 Тверь (4822)63-31-35
 Тольятти (8482)63-91-07
 Томск (3822)98-41-53
 Тула (4872)33-79-87
 Тюмень (3452)66-21-18
 Улан-Удэ (3012)59-97-51
 Ульяновск (8422)24-23-59
 Уфа (347)229-48-12
 Хабаровск (4212)92-98-04
 Чебоксары (8352)28-53-07
 Челябинск (351)202-03-61
 Череповец (8202)49-02-64
 Чита (3022)38-34-83
 Якутск (4112)23-90-97
 Ярославль (4852)69-52-93

Россия +7(495)268-04-70

Казахстан +7(7172)727-132

Киргизия +996(312)96-26-47

сайт: www.acvatix.nt-rt.ru || эл. почта: atv@nt-rt.ru