

По вопросам продаж и поддержки обращайтесь:

Алматы (7273)495-231
Ангарск (3955)60-70-56
Архангельск (8182)63-90-72
Астрахань (8512)99-46-04
Барнаул (3852)73-04-60
Белгород (4722)40-23-64
Благовещенск (4162)22-76-07
Брянск (4832)59-03-52
Владивосток (423)249-28-31
Владикавказ (8672)28-90-48
Владимир (4922)49-43-18
Волгоград (844)278-03-48
Вологда (8172)26-41-59
Воронеж (473)204-51-73
Екатеринбург (343)384-55-89
Иваново (4932)77-34-06
Ижевск (3412)26-03-58
Иркутск (395)279-98-46
Казань (843)206-01-48

Калининград (4012)72-03-81
Калуга (4842)92-23-67
Кемерово (3842)65-04-62
Киров (8332)68-02-04
Коломна (4966)23-41-49
Кострома (4942)77-07-48
Краснодар (861)203-40-90
Красноярск (391)204-63-61
Курган (3522)50-90-47
Курск (4712)77-13-04
Липецк (4742)52-20-81
Магнитогорск (3519)55-03-13
Москва (495)268-04-70
Мурманск (8152)59-64-93
Набережные Челны (8552)20-53-41
Нижний Новгород (831)429-08-12
Новокузнецк (3843)20-46-81
Новосибирск (383)227-86-73
Ноябрьск (3496)41-32-12

Омск (3812)21-46-40
Орел (4862)44-53-42
Оренбург (3532)37-68-04
Пенза (8412)22-31-16
Пермь (342)205-81-47
Петрозаводск (8142)55-98-37
Псков (8112)59-10-37
Ростов-на-Дону (863)308-18-15
Рязань (4912)46-61-64
Самара (846)206-03-16
Санкт-Петербург (812)309-46-40
Саранск (8342)22-96-24
Саратов (845)249-38-78
Севастополь (8692)22-31-93
Симферополь (3652)67-13-56
Смоленск (4812)29-41-54
Сочи (862)225-72-31
Ставрополь (8652)20-65-13
Сургут (3462)77-98-35

Сыктывкар (8212)25-95-17
Тамбов (4752)50-40-97
Тверь (4822)63-31-35
Тольятти (8482)63-91-07
Томск (3822)98-41-53
Тула (4872)33-79-87
Тюмень (3452)66-21-18
Улан-Удэ (3012)59-97-51
Ульяновск (8422)24-23-59
Уфа (347)229-48-12
Хабаровск (4212)92-98-04
Чебоксары (8352)28-53-07
Челябинск (351)202-03-61
Череповец (8202)49-02-64
Чита (3022)38-34-83
Якутск (4112)23-90-97
Ярославль (4852)69-52-93

Россия +7(495)268-04-70

Казахстан +7(7172)727-132

Киргизия +996(312)96-26-47

сайт: www.acvatix.nt-rt.ru || эл. почта: atv@nt-rt.ru



SQN70... / SQN71...

SQN74... / SQN75...

ТЕХНИЧЕСКИЕ ХАРАКТЕРИСТИКИ НА ЭЛЕКТРОМОТОРНЫЕ ПРИВОДЫ SQN7

Reversible electromotoric actuators for air dampers and valves of oil or gas burners of small to medium capacity.

The SQN7... and this Data Sheet are intended for use by OEMs which integrate the actuators in their products!

Use and features

The SQN7... actuators are designed for driving gas or air dampers of oil or gas burners of small to medium capacity, for load-dependent control of the fuel and combustion air volume:

- In connection with P-PI or PID controllers, such as the RWF40...
- Directly via the different types of burner controls, such as LFL..., LME..., LMG..., LMO..., LOA...
- In connection with 1- or 2-wire control or 3-position controllers

- All types of actuators feature:
 - Impact-proof and heat-resistant plastic housings
 - Screw terminals for the electrical connections
 - Maintenance-free gear train, which can be disengaged
 - Internal position indication
 - Easy-to-adjust end and auxiliary switches for adjusting the switching points
 - Integrated electronic circuits
- Holding torque:
 - SQN70... / SQN71... / SQN75... 0.7...1.3 Nm
 - SQN74... 0.7 Nm
- Running time:
 - SQN70... / SQN71... / SQN75... 4...30 s
 - SQN74... 4 s
- Direction of rotation:
 - SQN70... / SQN74... counterclockwise
 - SQN71... / SQN75... clockwise
- SQN74... / SQN75...
 - Fixing holes and cable entries
 - Equivalent to actuators of the same category made by Conectron and Berger

Warning notes



To avoid injury to persons, damage to property or the environment, the following warning notes should be observed!

Do not interfere with or modify the actuators!

- All activities (mounting, installation and service work, etc.) must be performed by qualified staff
- Before making any wiring changes in the connection area, completely isolate the plant from mains supply (all-polar disconnection). Ensure that the plant cannot be inadvertently switched on again and that it is indeed dead. If not observed, there is a risk of electric shock hazard
- Ensure protection against electric shock hazard by providing adequate protection for the connection terminals and by securing the housing cover
- Each time work has been carried out (mounting, installation, service work, etc.), check to ensure that wiring is in an orderly state
- Fall or shock can adversely affect the safety functions. Such actuators must not be put into operation, even if they do not exhibit any damage

Mounting notes

- Ensure that the relevant national safety regulations are complied with

Standards and certificates



Conformity to EEC directives
- Electromagnetic compatibility EMC (immunity)
- Low-voltage directive

2004/108/EC
2006/95/EC



ISO 9001: 2000
Cert. 00739



ISO 14001: 2004
Cert. 38233



Only valid for
SQN70.xxxRxx
SQN71.xxxRxx

Disposal notes



The actuators contain electrical and electronic components and must not be disposed of together with household waste.
Local and currently valid legislation must be observed.

Mechanical design

Housing	<ul style="list-style-type: none">- Made of impact-proof and heat-resistant plastic- The housing accommodates:<ul style="list-style-type: none">– The reversible synchronous motor with gear train, which can be disengaged– The camshaft of the control section– The relays, depending on the type of actuator– The switches, connected to the terminals via the printed circuit board <p>Color: SQN70... / SQN71...: Gear train housing dark-grey, cover light-grey SQN74... / SQN75...: Gear train housing black, cover black</p>
Drive motor	<ul style="list-style-type: none">- Reversible and locking-proof synchronous motor
Coupling	<ul style="list-style-type: none">- Drive shaft can be manually disengaged from the gear train and motor (by pressing pin «K»)- Automatic reengagement
Adjustment of switching points	<ul style="list-style-type: none">- By means of adjustable cams- Scales beside the cams indicate the angle of the switching point- Assignment of cams to the end and auxiliary switches is color-coded (refer to «Connection diagrams»)- Some of the cam feature fine adjustment; they can be adjusted with a standard screwdriver- The other cams can be adjusted manually or with the enclosed hook-spanner or a similar tool
Position indication	<ul style="list-style-type: none">- Internally: Scale at the beginning of the camshaft on the gear train side
Electrical connections	<ul style="list-style-type: none">- Refer to «Technical data»
Gear train	<ul style="list-style-type: none">- Maintenance-free
Drive shaft	<ul style="list-style-type: none">- Made of black-finished steel- Ready fitted to the front of the gear train- Different versions available
Mounting and fixing	<ul style="list-style-type: none">- Front of the gear train is used as the mounting surface- Actuator is secured via through-holes

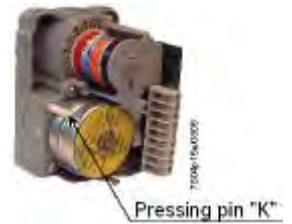

Special versions for fitting potentiometer

Fitting a potentiometer	<p>Certain types of actuators are supplied ready prepared for fitting a potentiometer. These actuators differ from the basic type only in that the cover is higher. They are prepared for housing the potentiometer. Accessories are not required. With these types of actuators, the third digit after the dot in the actuator's type reference is an «8».</p> <p>Example: SQN7x.xx8Axx → version for fitting a potentiometer, mounted higher cover AGA34</p> <p>With the other types of actuators which are suited for fitting a potentiometer, the higher cover AGA34 must be ordered (refer to «Ordering»).</p> <p>The required type of potentiometer is to be ordered as a separate item (refer to «Ordering»).</p>
-------------------------	---

Type summary (other types of actuators available on request)

Diagram No.	Drive shaft No. ¹⁾	Running time ²⁾ for 90° s	Nominal torque ⁶⁾ (max.) Nm	Holding torque Nm	AS ⁷⁾ pcs.	Relay pcs.	Pot. ^{9) 10)}	Length of housing ¹⁾ mm	Types for mains voltage / mains frequency		SQN7... replaces type
									AC 230 V ⁴⁾ +10 % -15 % 50...60 Hz	AC 115 V ³⁾ +10 % -15 % 50...60 Hz	
Actuators SQN70... / counterclockwise rotation⁸⁾											
2	0	4	1.5	0.7	2	2	---	117	SQN70.224A20	---	---
4	0	4	1.5	0.7	2	3	---	117	SQN70.244A20	---	SQN30.121A2700
6	0	4	1.5	0.7	2	---	10)	80	SQN70.264A20	---	SQN30.101A2700
9	0	4	1.5	0.7	2	1	---	117	SQN70.294A20	---	SQN30.111A2700
2	0	6	1.5	0.7	2	2	---	117	SQN70.324A20	---	SQN30.151A2700
2	0	12	2.5	1.2	2	2	---	117	SQN70.424A20	---	---
5	0	12	2.5	1.2	2	3	---	117	SQN70.454A20	---	---
6	0	12	2.5	1.2	2	---	10)	80	SQN70.464A20	---	---
6	3	12	2.5	1.2	2	---	10)	80	SQN70.464A23	---	---
2	0	30	2.5	1.3	2	2	---	117	SQN70.624A20	---	---
6	0	30	2.5	1.3	2	---	10)	80	SQN70.664A20	---	SQN30.401A2700
6	3	30	2.5	1.3	2	---	10)	80	SQN70.664A23	---	SQN30.401A2730
Actuators SQN70... / counterclockwise rotation⁸⁾ / UL «Registered» for use in U.S. and Canada											
0	0	30	2.5	1.3	1	---	10)	80	---	SQN70.603R10	---
Actuators SQN71... / clockwise rotation⁸⁾											
4	0	4	1.5	0.7	2	2	---	117	SQN71.244A20	---	SQN31.121A2700
6	0	4	1.5	0.7	2	---	10)	80	SQN71.264A20	---	SQN31.101A2700
2	0	12	2.5	1.2	2	2	---	117	SQN71.424A20	---	---
4	0	12	2.5	1.2	2	2	---	117	SQN71.444A20	---	---
5	0	12	2.5	1.2	2	3	---	117	SQN71.454A20	---	---
6	1	12	2.5	1.2	2	---	10)	80	SQN71.464A21	---	---
2	3	30	2.5	1.3	2	2	---	117	SQN71.624A23	---	---
6	0	30	2.5	1.3	2	---	10)	80	SQN71.664A20	SQN71.664A10	SQN31.401A2700
6	3	30	2.5	1.3	2	---	9)	117	SQN71.669A23	---	---
9	0	30	2.5	1.3	2	1	---	117	SQN71.694A20	---	---
Actuators SQN71... / clockwise rotation⁸⁾ / UL «Registered» for use in U.S. and Canada											
0	9	4	1.5	0.7	1	---	10)	80	---	SQN71.203R19	---
0	9	12	2.5	1.2	1	---	10)	80	---	SQN71.403R19	---
0	0	30	2.5	1.3	1	---	10)	80	---	SQN71.603R10	---
0	9	30	2.5	1.3	1	---	10)	80	---	SQN71.603R19	---
0	0	30	2.5	1.3	1	---	9)	84	---	SQN71.608R10⁵⁾	---
0	0	30	2.5	1.3	1	---	9)	84	SQN71.608R20⁵⁾	---	---

The UL-registered types of actuators

- also meet CE requirements
- are of the same basic design as the equivalent standard types

The only difference between the standard versions and the UL-registered versions is the use of other materials, especially plastics. In addition, the UL-registered versions are supplied complete with an adapter for use in the U.S. and Canada (refer to «Dimensions»).

Type summary / cont'd (other types of actuators available on request)

Diagram No.	Drive shaft No. 1)	Running time 2) for 90° s	Nominal torque 6) (max.) Nm	Holding torque Nm	AS 7) pcs.	Relay pcs.	Pot. 9) 10)	Length of housing 1) mm	Types for mains voltage / mains frequency		SQN7... replaces type
									AC 230 V 4) +10 % -15 % 50...60 Hz	AC 115 V 3) +10 % -15 % 50...60 Hz	
Actuators SQN74... / counterclockwise rotation 8)											
5	1	4	1,5	0,7	4	3	9)	115	SQN74.254A21	---	---
9	1	4	1,5	0,7	2	1	9)	115	SQN74.294A21	---	---
9	1	30	2,5	1,3	2	1	9)	115	SQN74.694A21	---	---
Actuators SQN75... / clockwise rotation 8)											
2	1	4	1,5	0,7	2	2	---	115	SQN75.224A21	---	---
2	6	4	1,5	0,7	4	2	---	115	SQN75.224A26	---	---
3	1	4	1,5	0,7	4	2	---	115	SQN75.236A21	---	---
4	1	4	1,5	0,7	2	3	---	115	SQN75.244A21	---	---
4	6	4	1,5	0,7	2	3	---	115	SQN75.244A26	---	---
9	1	4	1,5	0,7	2	1	9)	115	SQN75.294A21	---	---
9	1	4	1,5	0,7	4	1	9)	115	SQN75.294A26	---	---
F	1	4	1,5	0,7	4	2	---	115	SQN75.2F6A21	---	---
F	1	12	2,5	1,2	4	2	---	115	SQN75.4F6A21	---	---
2	1	12	2,5	1,2	2	2	---	115	SQN75.424A21	---	---
4	1	12	2,5	1,2	2	3	---	115	SQN75.444A21	---	---
9	1	12	2,5	1,2	2	1	9)	115	SQN75.494A21	---	---
2	6	23	2,5	1,2	4	2	---	115	SQN75.524A26	---	---
K	1	30	2,5	1,3	2	---	9)	115	SQN75.6K4A21	SQN75.6K4A11	---
2	6	30	2,5	1,3	2	2	---	115	SQN75.624A26	---	---
6	6	30	2,5	1,3	4	---	9)	115	SQN75.664A26	---	---
9	1	30	2,5	1,3	2	1	9)	115	SQN75.694A21	---	---

Legend

- 1) Refer to «Dimensions»
- 2) At 60 Hz, running times are about 20 % shorter
- 3) AC 115 V +10 % / -15 % possible, but in the case of undervoltage, torque is reduced by about 20 %
- 4) AC 230 V +10 % / -15 % possible, but in the case of undervoltage, torque is reduced by about 20 %
- 5) On request
- 6) Under nominal conditions; under extreme conditions (e.g. +60 °C, AC 230 V -15 %) approx. -25 %
- 7) Auxiliary switches (in addition to the 2 end switches)
- 8) When facing the drive shaft and when control voltage is supplied to end switch I
- 9) Suited for direct fitting of potentiometer (refer to «Fitting a potentiometer»)
- 10) Suited for fitting potentiometer. Cover AGA34 to be ordered as a separate item

Actuator

refer to «Type reference»

Potentiometer ASZ...

refer to Data Sheet N7921
refer to Mounting Instruction M7921



Mounting kit

AGA70.3

- For mounting the SQN70... / SQN71... in place of the SQN3...
- Fitted to the SQN70... / SQN71... with a self-tapping screw (included as standard)



Cover

AGA34

- For SQN70... / SQN71... backfitting with potentiometer ASZxx.3x

Technical data

General actuator data

Actuator

Mains voltage	AC 230 V –15 % +10 % AC 115 V –15 % +10 %						
Mains frequency	50...60 Hz ± 6 %						
Drive motor	Synchronous motor						
Power consumption	6 VA						
Angular adjustment	Max. 160°, scale range 0...130°						
Mounting position	Optional						
Degree of protection							
- All types	IP40 to DIN 40050, provided adequate cable entries and fixing screws are used						
- SQN74... / SQN75...	IP20 to DIN 40050, provided lateral knock-out hole for cable is used						
Safety class							
- SQN70... / SQN71...	II to DIN EN 60730						
- SQN74... / SQN75...	I to DIN EN 60730						
Cable entry							
- SQN70... / SQN71...	Insertable threaded cable gland holder for 2 x Pg9, no locknut required						
- SQN74... / SQN75...	Openings for locknut for fixing cable glands						
	<table><thead><tr><th></th><th>Type of locknut</th></tr></thead><tbody><tr><td>1 x Pg9</td><td>M Pg9 DIN 46320 MS</td></tr><tr><td>1 x Pg11</td><td>M Pg11 DIN 46320 MS</td></tr></tbody></table>		Type of locknut	1 x Pg9	M Pg9 DIN 46320 MS	1 x Pg11	M Pg11 DIN 46320 MS
	Type of locknut						
1 x Pg9	M Pg9 DIN 46320 MS						
1 x Pg11	M Pg11 DIN 46320 MS						
	Additional lateral knockout hole for loose introduction of 2 cables with a maximum dia. of 6 mm, cable strain relief to be provided by the user (also refer to «Degree of protection») Pg glands and locknuts are not part of the delivery						
Cable connections	Screw terminals for min. 0.5 mm ² and max. 2.5 mm ² cross-sectional area						
Ferrules	Matching the dia. of the stranded wire						
Direction of rotation	Refer to «Type summary»						
Nominal and holding torque	Refer to «Type summary»						
Running times	Refer to «Type summary»						
Weight (average)	Approx. 500 g						
On time	60 % max. 3 min. continuous operation						
Backlash between drive motor and drive shaft							
- As supplied	$\leq 1.2^\circ \pm 0.3^\circ$						
- After 250,000 cycles	$\leq 1.5^\circ \pm 0.3^\circ$						

End and auxiliary switches

Number of end switches	2
Number of auxiliary switches	Refer to «Type summary»
Actuation	Via camshaft, color-coded cams (refer to «Connection diagrams») Switches with fine adjustment - SQN70... / SQN71... : II and III - SQN74... / SQN75... : III and IV
Breaking voltage	AC 24...250 V
Adjustment of cams	
- Without fine adjustment	1°
- With fine adjustment	Infinitely
Perm. amperage at $\cos \varphi = 0.9$: (values in parentheses: short-time peaks for max. 0.5 s)	
• Connection diagram ①	
– Terminals 1, 2, 3, 4	0.5 A
– Terminals 5, 6, 7	1 A (7 A)
• Connection diagram ①	
– Terminals 1, 2, 6, 7	0.5 A
– Terminals 3, 4	1 A (7 A)
• Connection diagram ②	
– Terminals 1, 2, 3, 8	0.5 A
– Terminal 4, 5	2 A (14 A)
– Terminal 6, 7	1 A (7 A)
• Connection diagram ③	
– Terminals 1, 2, 3, 8, 11	0.5 A
– Terminals 4, 5, 7, 10	1 A (7 A)
• Connection diagram ④	
– Terminals 1, 3, 8	0.5 A
– Terminal 4, 5	3 A (14 A)
– Terminal 6, 7	1 A (7 A)
• Connection diagram ⑤	
– Terminals 1, 2, 3, 8	0.5 A
– Terminal 4, 5	2 A (14 A)
– Terminal 6, 7	1 A (7 A)
• Connection diagram ⑥	
– Terminals 1, 2, 3, 4, 5	0.5 A
– Terminal 6, 7, 8	1 A (7 A)
• Connection diagram ⑨	
– Terminals 1, 2, 3, 4, 5, 8	0.5 A
– Terminal 6, 7	1 A (7 A)
• Connection diagram ①	
– Terminals 2...7	0.5 A
– Terminals 1, 8, 9	1 A (7 A)
• Connection diagram ①	
– Terminals 1, 2	0.5 A
– Terminals 3, 4, 5, 6, 7, 8	1 A (7 A)

Technical data (cont'd)

Environmental conditions

Storage	DIN EN 60721-3-1
Climatic conditions	Class 1K3
Mechanical conditions	Class 1M2
Temperature range	-20...+60 °C
Humidity	<95 % r.h.
Transport	DIN EN 60721-3-2
Climatic conditions	Class 2K2
Mechanical conditions	Class 2M2
Temperature range	-50...+60 °C
Humidity	<95 % r.h.
Operation	DIN EN 60721-3-3
Climatic conditions	Class 3K5
Mechanical conditions	Class 3M2
Temperature range	-20...+60 °C
Humidity	<95 % r.h.



Condensation, formation of ice and ingress of water are not permitted!

Function

A synchronous motor drives the camshaft via a gear train. The camshaft actuates the end and auxiliary switches. Using the associated cam, the switching position of each end and auxiliary switch can be adjusted within the working range. Some of the actuator versions are equipped with electronic modules, which perform auxiliary functions in connection with the end and auxiliary switches, or with external devices, such as controllers (refer to «Connection diagrams»). The functions and technical data of both lines of actuators SQN70... / SQN71... and SQN74... / SQN75... are nearly identical.

Replacement of SQN30... / SQN31...

The «Type summary» contains actuators type **SQN3...**, which can be replaced by SQN70... / SQN71... with the help of a mounting kit (refer to «Ordering»).

The **SQN30...** and **SQN31...** contained in the «Type summary»

- Refer to the SQN7... AC 230 V versions
- are versions **with no** facility for fitting a potentiometer (refer to Data Sheet N7808)

Mechanical adaptations are not normally required.

To be noted are the different terminal assignments used with the 2 lines of actuators.

Connection diagrams



The following connection diagrams show the start position as supplied:

- End switch position II «Closed»
- Dead

No. ② → LGB22... / LGB32... / LME22... / LME23... / LMG22...

2-stage or modulating operation → prepurging at nominal load position «NL»

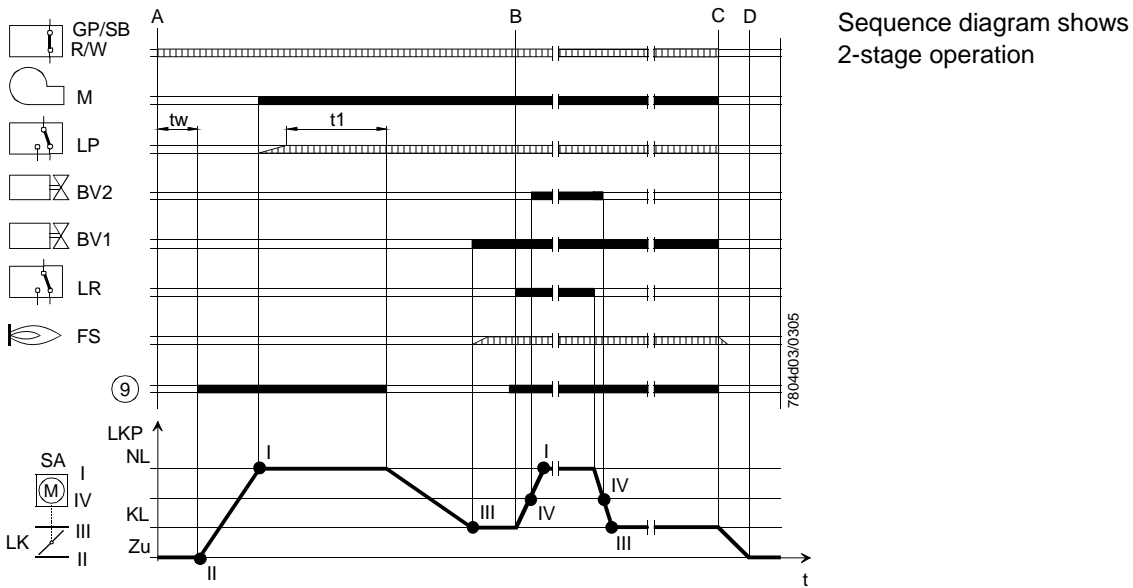
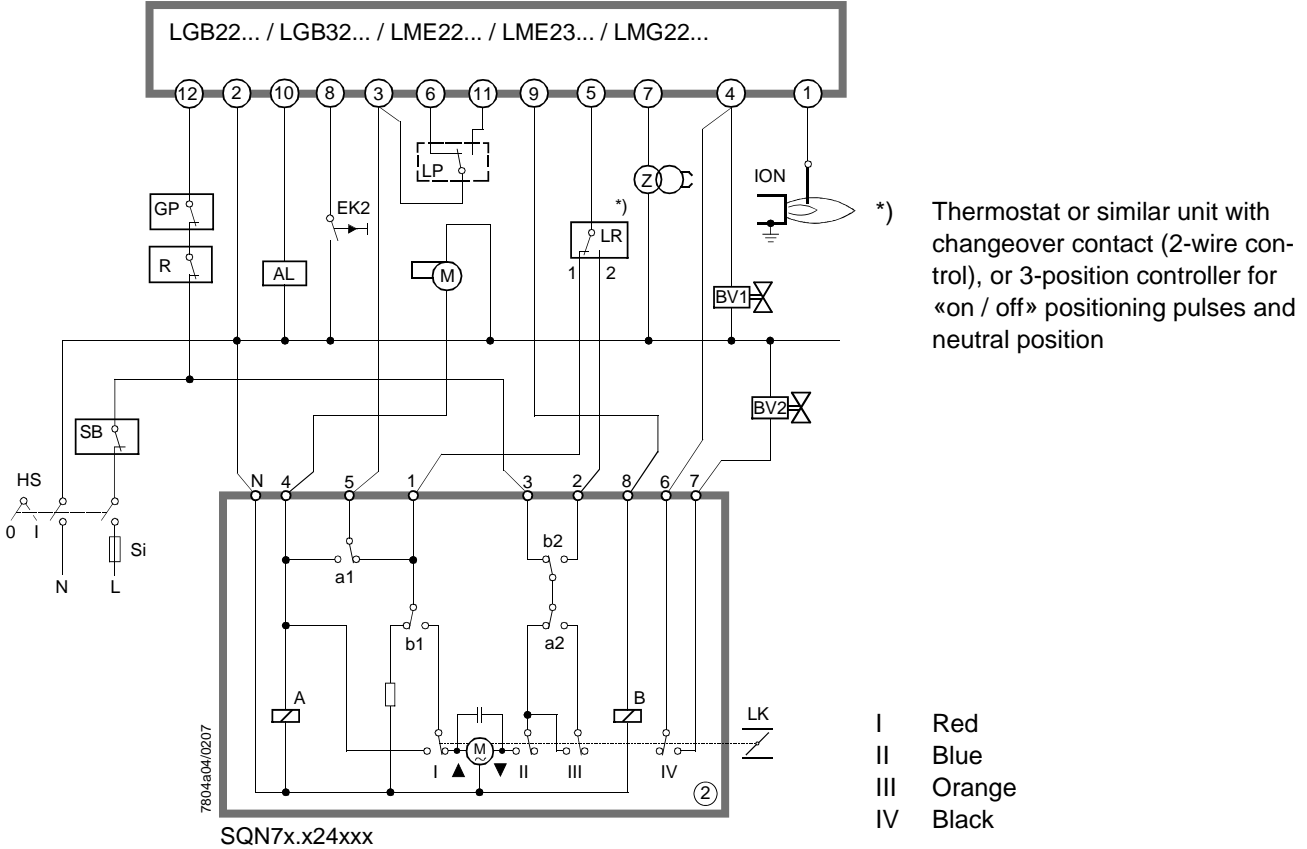

2-stage operation → prepurging at low-fire position «KL»

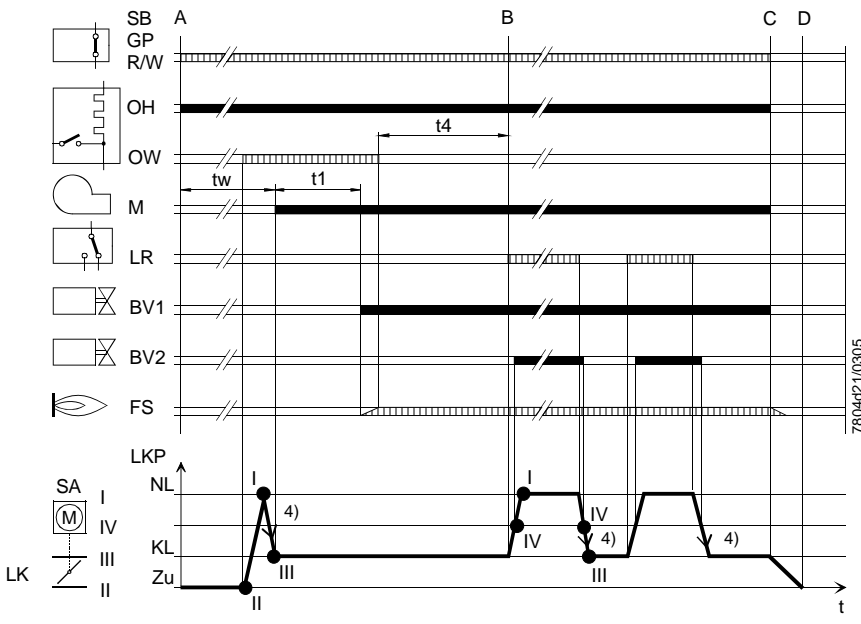
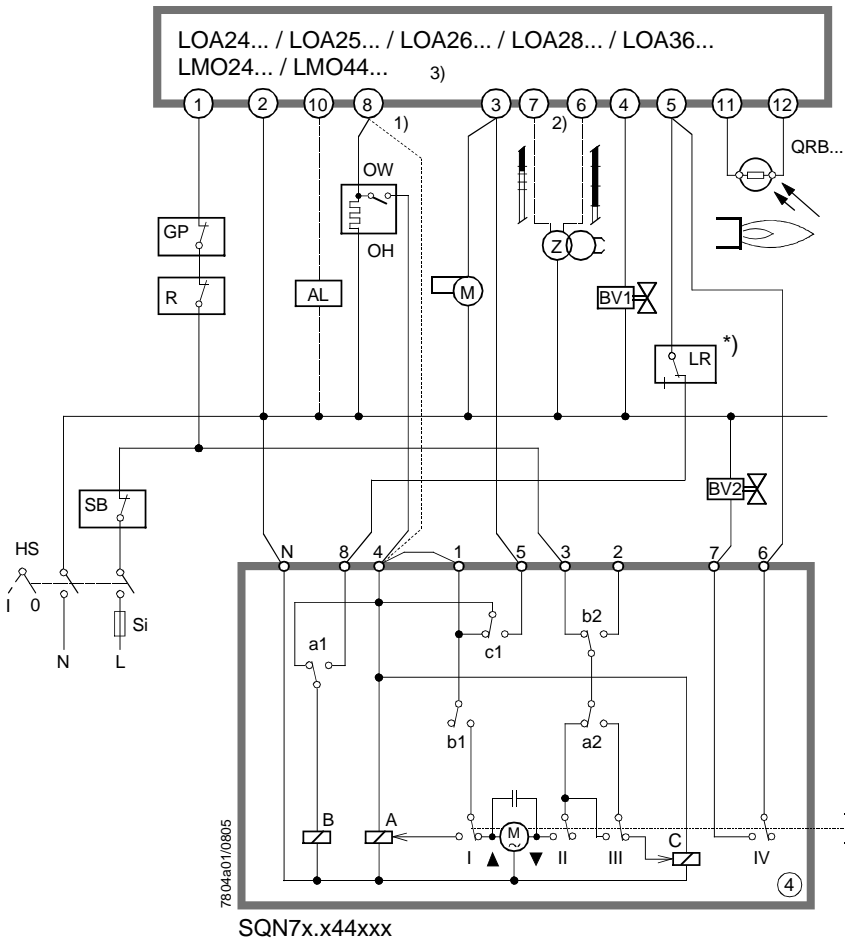

Connection diagrams (cont'd)

No. ④ → LGB21... / LME21... / LMG21...

2-stage operation → prepurging at low-fire position «KL»

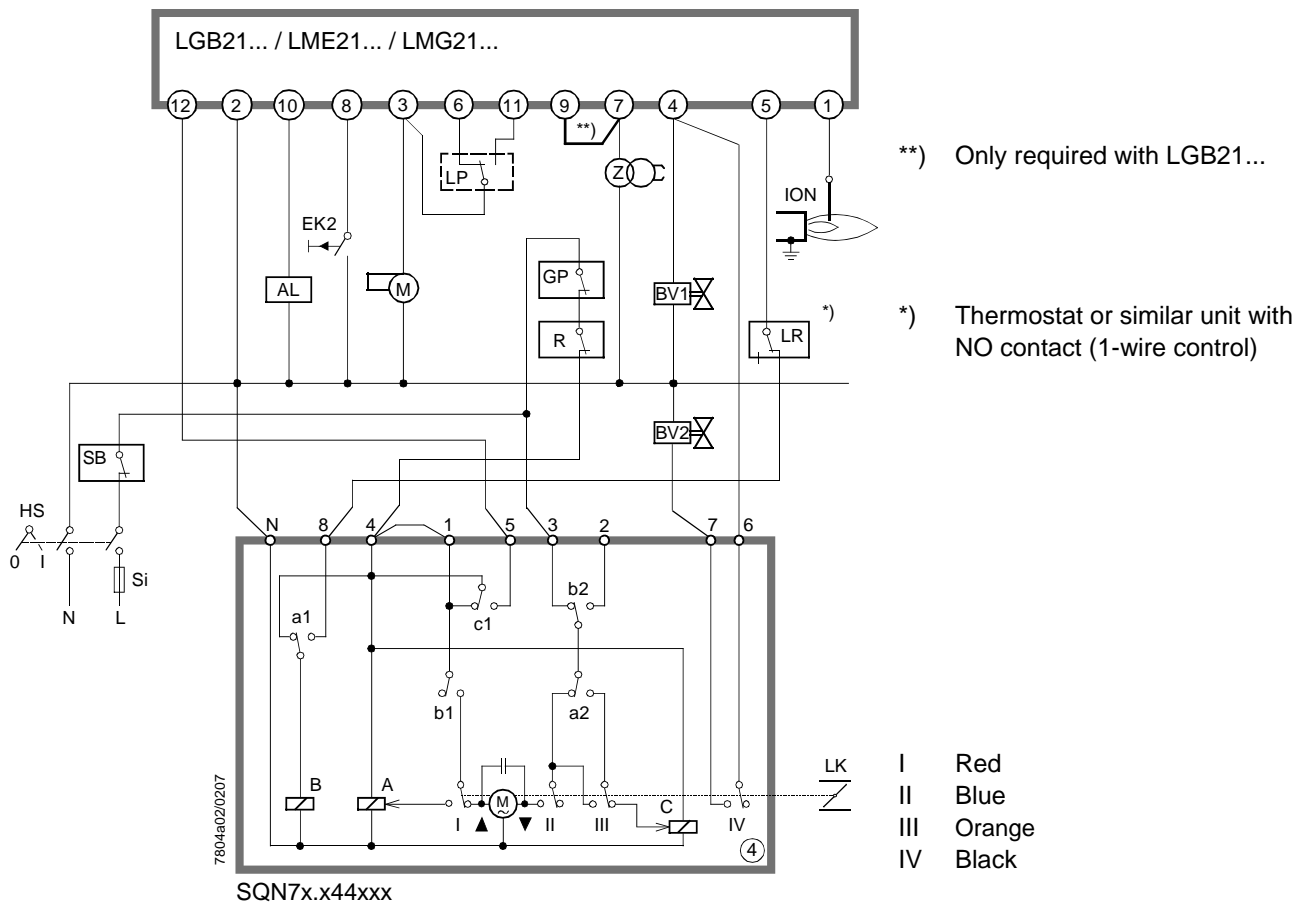

** Only required with LGB21...

*) Thermostat or similar unit with NO contact (1-wire control)

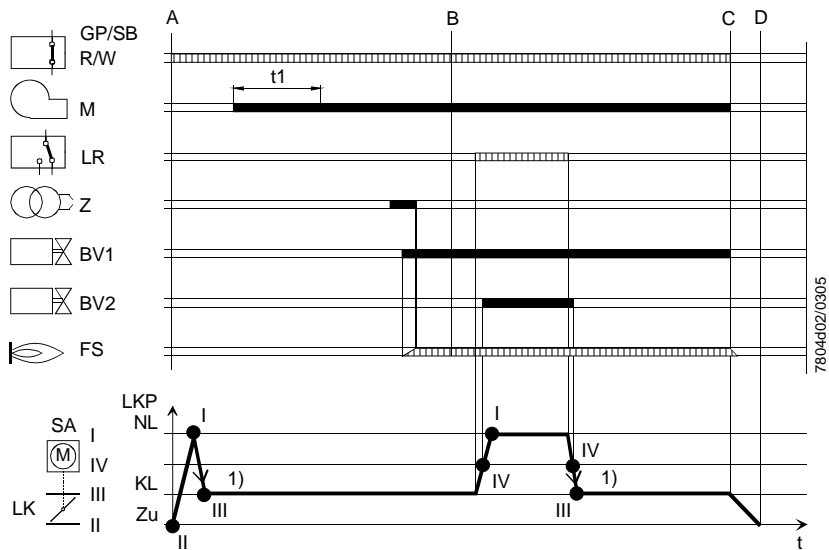

1) Required position is approached from only one side to eliminate switching differential (compensation of backlash)

Connection diagrams (cont'd)

No. ⑤ → LME22... / LME23... / LGB22... / LGB32... / LMG22...

2-stage operation → prepurging at nominal load position «NL»

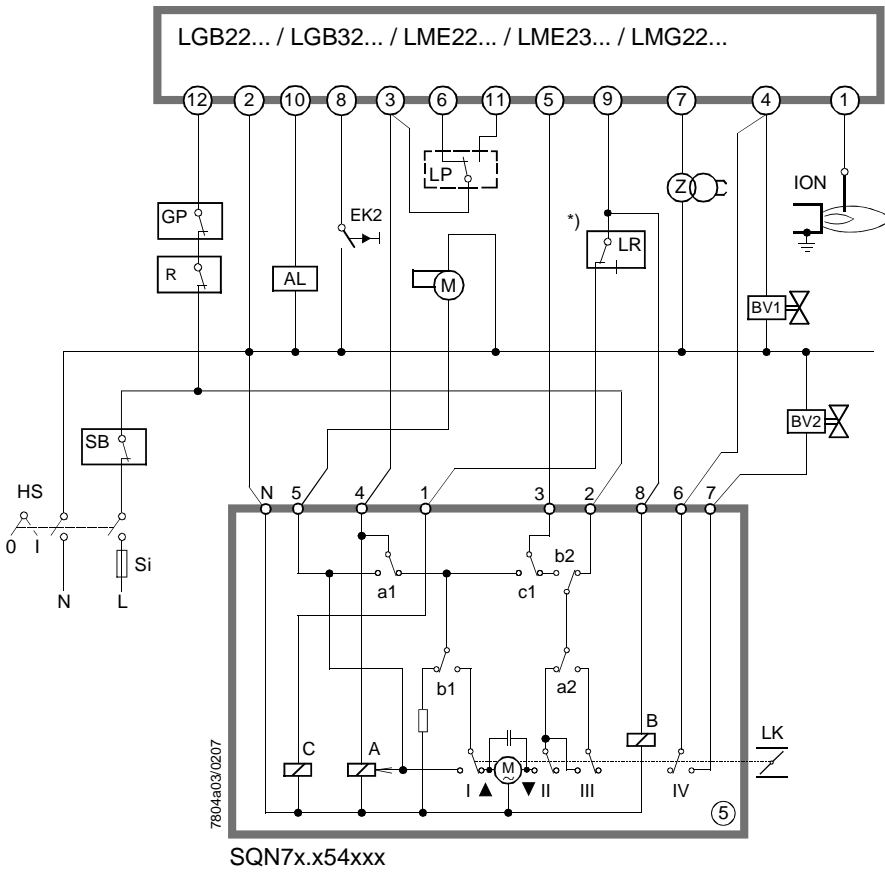

*) Thermostat or similar unit with NO contact (1-wire control)

- I Red
- II Blue
- III Orange
- IV Black

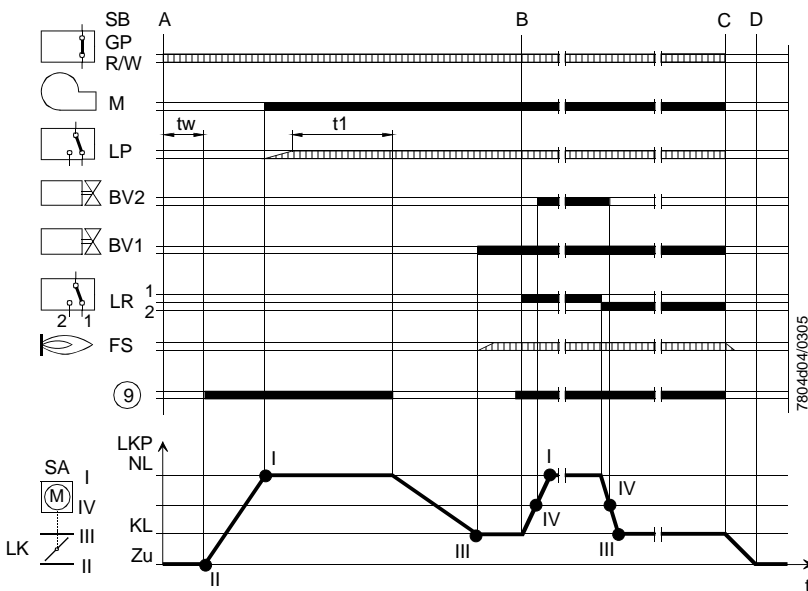

2-stage or modulating operation → prepurging at nominal load position «NL»

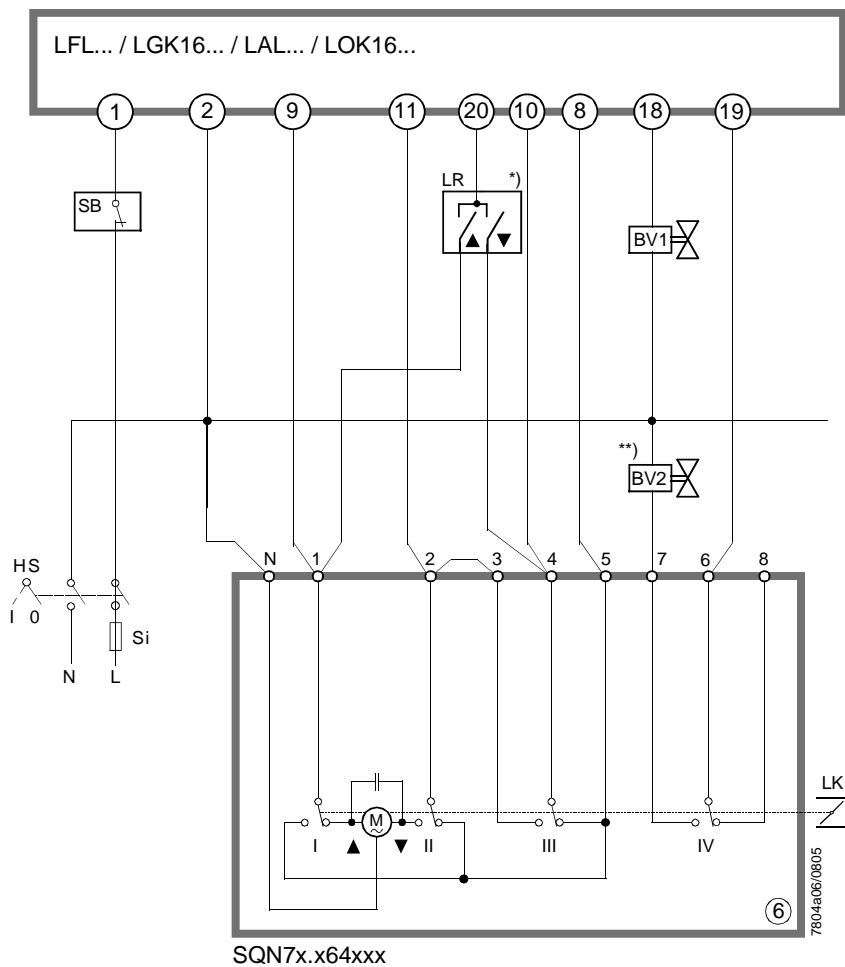

*) Thermostat or similar unit with changeover contact or 3-position controller for «on / off» positioning pulses and neutral position

***) In the case of modulating operation, fuel valve «BV2» is replaced by a gas control valve «RV»

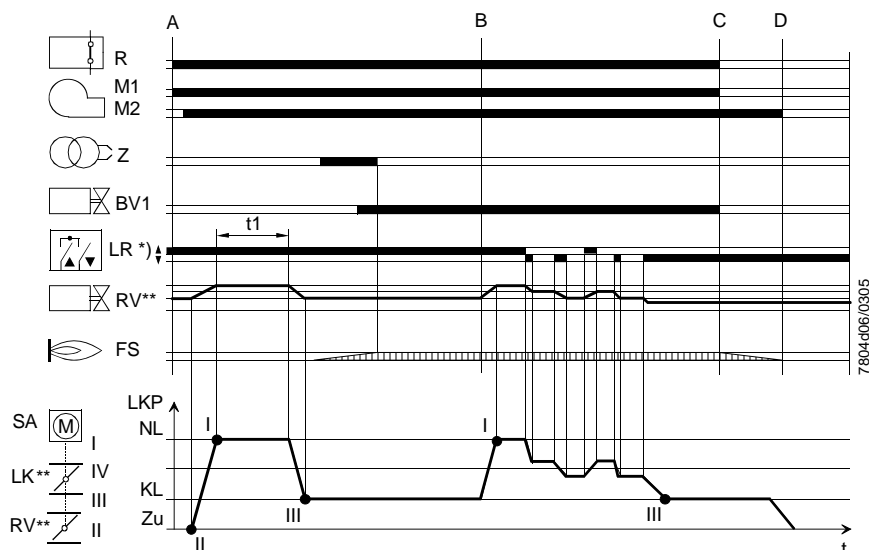

Program sequence diagram shows modulating operation.

2-stage operation → prepurging at low-fire position «KL»

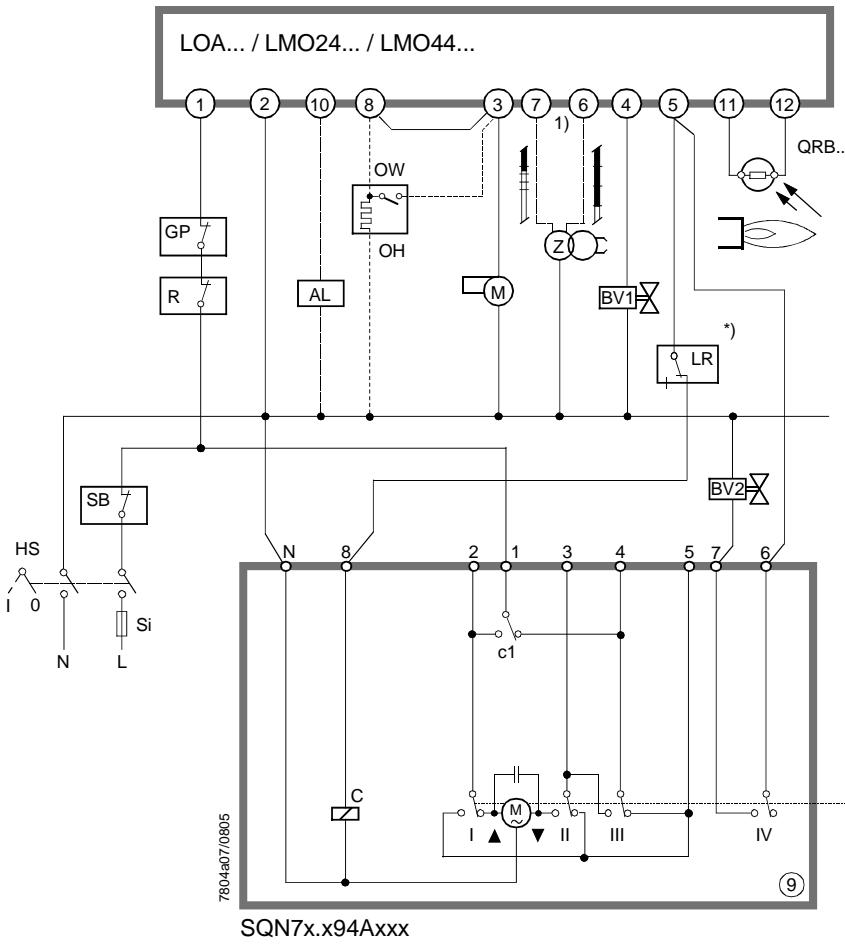

1) Refer to Data Sheets N7118 and N7130

*) Thermostat or similar unit with NO contact (1-wire control)

SQN7x.x94Axxx

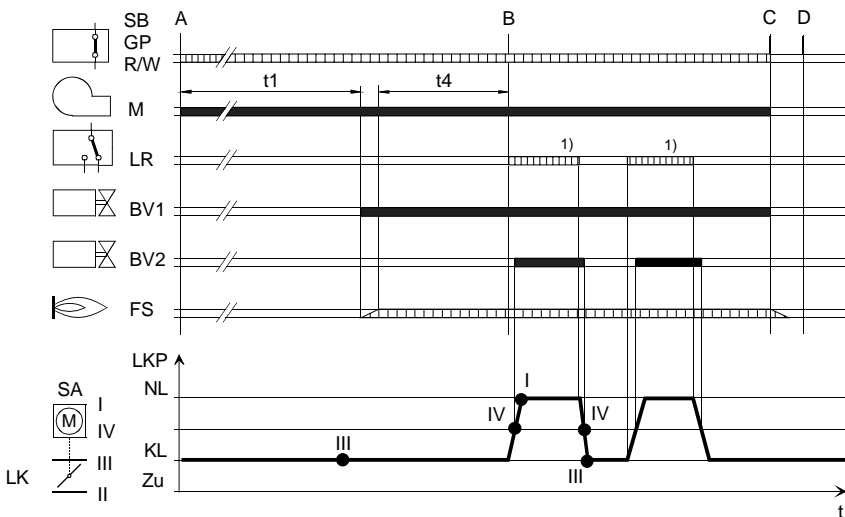

Program sequence without oil preheater

In the case of burner OFF, the air damper will stop at position «KL». To be noted are the heat losses that normally occur during off times.

2-stage operation → prepurging at nominal load position «NL»

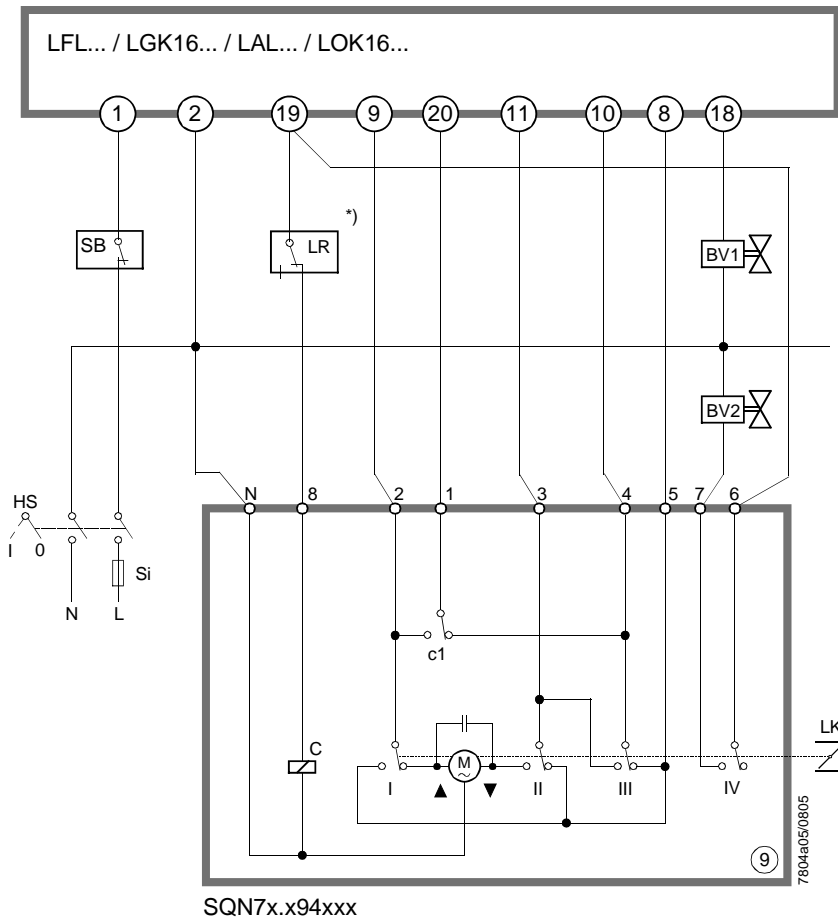

*) Thermostat or similar unit with NO contact (1-wire control)

- I Red
- II Blue
- III Orange
- IV Black

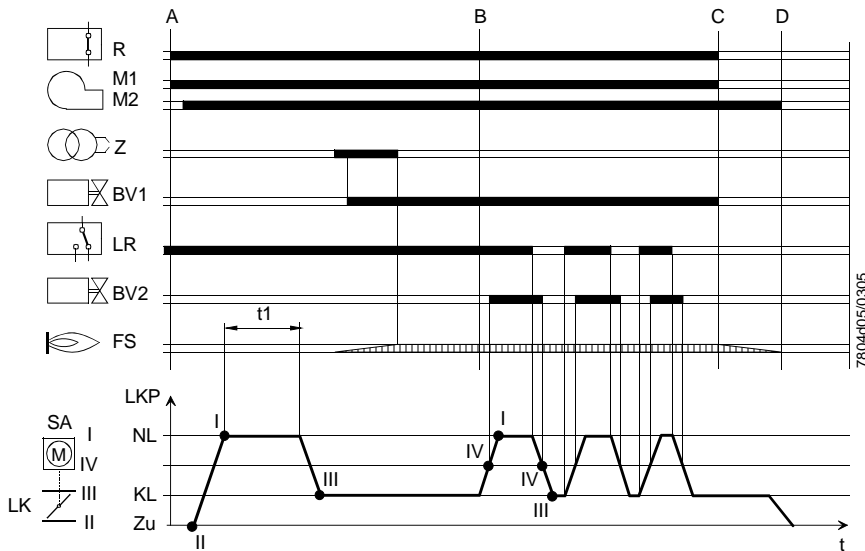

Connection diagrams (cont'd)

No. (F) → LAL... / LFL...

3-stage operation → prepurging at nominal load position («ST.3»)

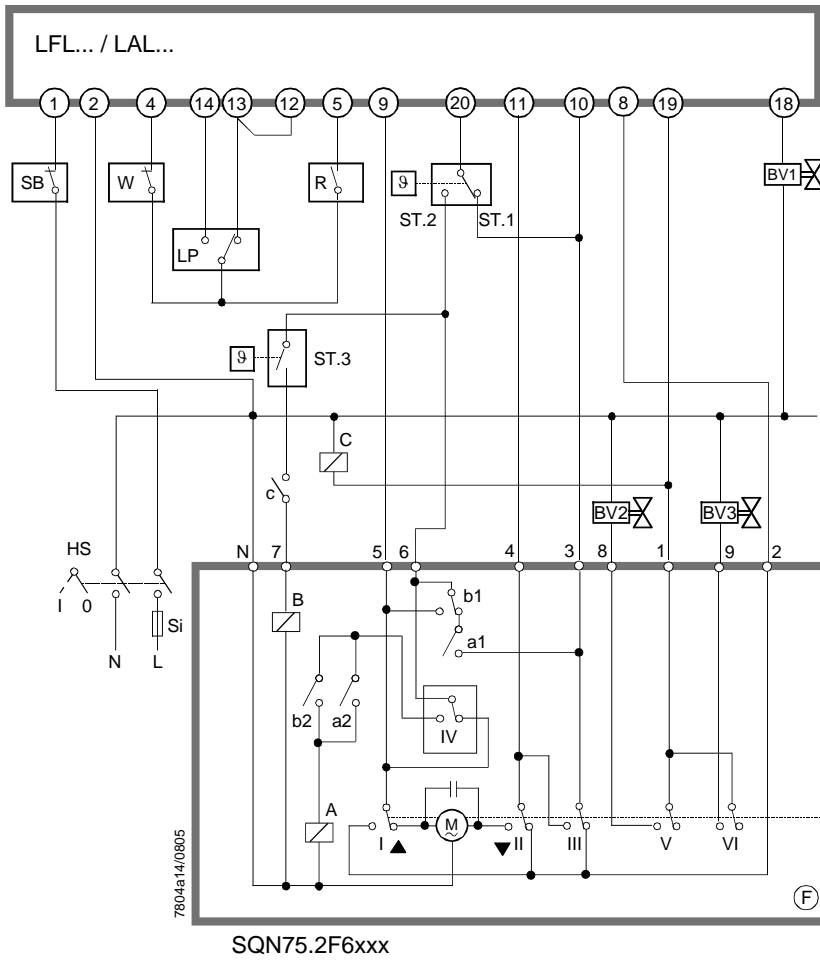

ST.1...3 Stage 1...3

C External auxiliary relay

- I Red
- II Blue
- III Orange
- IV Yellow
- V Black
- VI Green

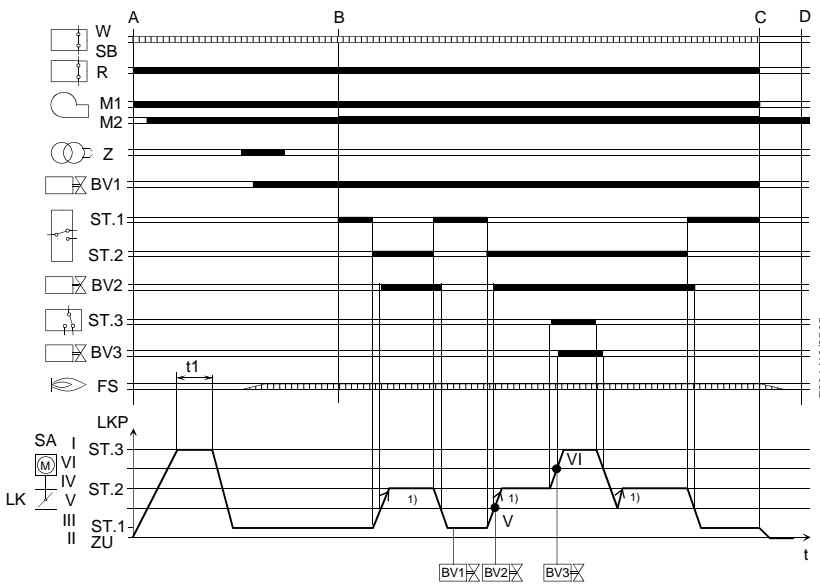

1) Required position is approached from only one side to eliminate switching differential (compensation of backlash)

Connection diagrams (cont'd)

No. ① → Universal use

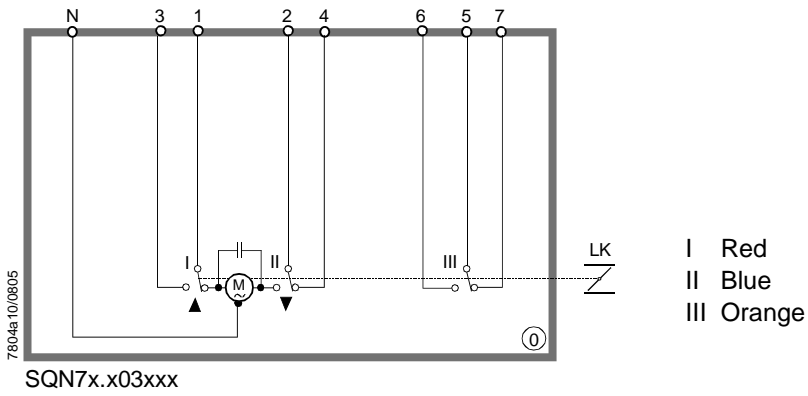

No. ② → Universal use

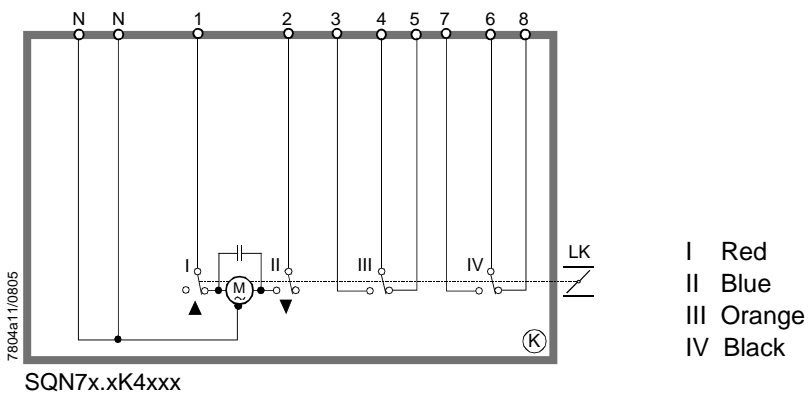

No. ① → TMG740 / TMO720

2-stage operation → prepurging at nominal load position «NL»

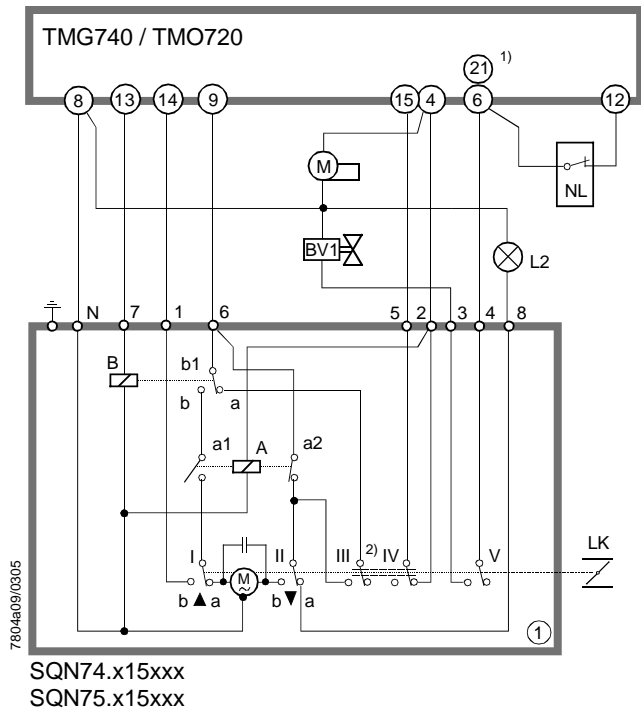

1) TMO720 terminal no. 6
TMG740 terminal no. 21

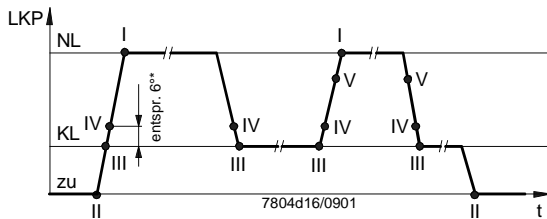

2) Cams of auxiliary switches III and IV rigidly connected

- I Red
- II Blue
- III Orange
- IV Orange
- V Black



- **TMG... / TMO... are burner controls of other manufacture.**
The user must check with the supplier of the TMG... / TMO... the proposed combination with the actuator from a safety point of view and with regard to the type of burner control used.
The user will assume full responsibility for this application.
- **Connection diagram no. ① corresponds to connection diagram no. ③ of the SQN3...**

Legend

No. ②	Number of internal diagram. Appears at the second position after the dot in the type reference
I / II	End switches
III / IV / V	Auxiliary switches
AL	Remote indication of lockout (alarm)
BV1	Fuel valve stage 1
BV2	Fuel valve stage 2
BV3	Fuel valve stage 3
EK2	External remote reset button
ION	Ionization probe
FS	Flame signal
GL	Gas / air ratio controller
GP	Gas pressure switch
HS	Main switch
KL	Low-fire
L	Live conductor
LK	Air damper
LKP	Air damper position
LP	Air pressure switch
LR	Load controller
M	Burner or fan motor
Ⓜ	Actuator's synchronous motor
M1	Without postpurge
M2	With postpurge
N	Neutral conductor
NL	Nominal load
OH	Oil preheater
OW	Oil preheater's readiness contact
QRB...	Photoresistive flame detector
R	Temperature or pressure controller
	Relay
RV	Control valve
SA	Actuator
Si	External primary fuse, as specified in the Data Sheet of the relevant burner control
SB	Safety limiter
ST...	Stage
t... / T...	Program times (refer to the Data Sheet of the relevant burner control)
TSA	Safety time
	Resistance
Z	Ignition transformer
CLOSED	Damper fully closed
▲	Direction of rotation OPEN
▼	Direction of rotation CLOSE

Program sequence diagrams

A	Burner ON
A – B	Startup of burner
B – C	Burner operation / load control operation (modulating or 2-stage)
C	Burner OFF
C – D	Overrun time
D	End of program, burner control ready for new start

Dimensions

Dimensions in mm

SQN70... / SQN71...

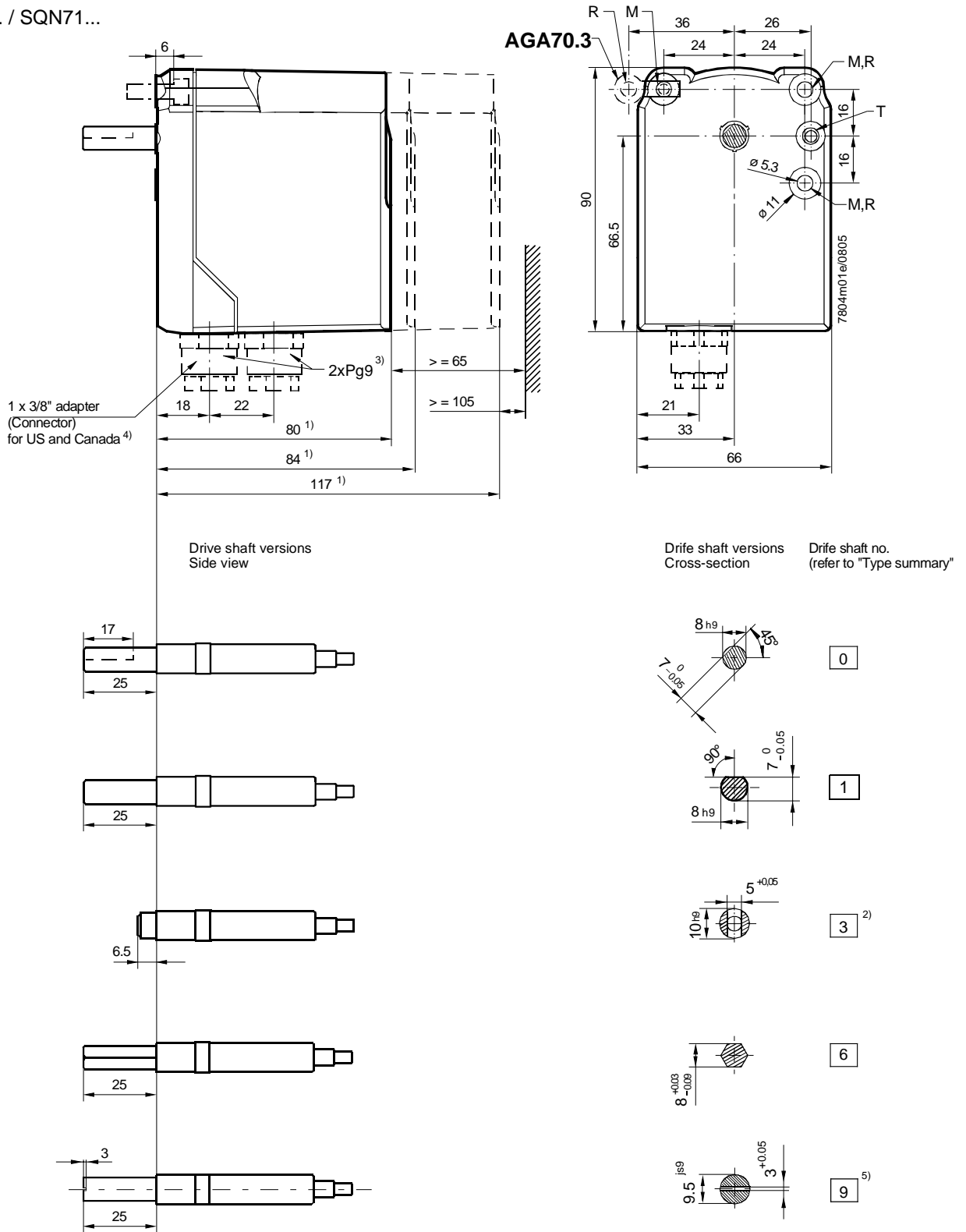

All drive shafts shown in end switch position II «Closed» as supplied.

- 1) Housing length depending on the type of actuator (refer to «Type summary»)
- 2) Center groove: 6.3 mm deep
Hole 5.1 mm dia.: 16.5 mm deep (incl. center groove depth)
- 3) Not included in supply
- 4) Supplied with actuators type SQN7x.xxxRxx
- 5) Groove does not serve for transmission of force

- R Fixing positions matched to the SQN3... (for 1-to-1 replacement by SQN70... / SQN71...) requiring AGA70.3
- M Through-hole 5.3 mm dia.
- T Knockout hole 5.3 mm dia.

SQN74... / SQN75...

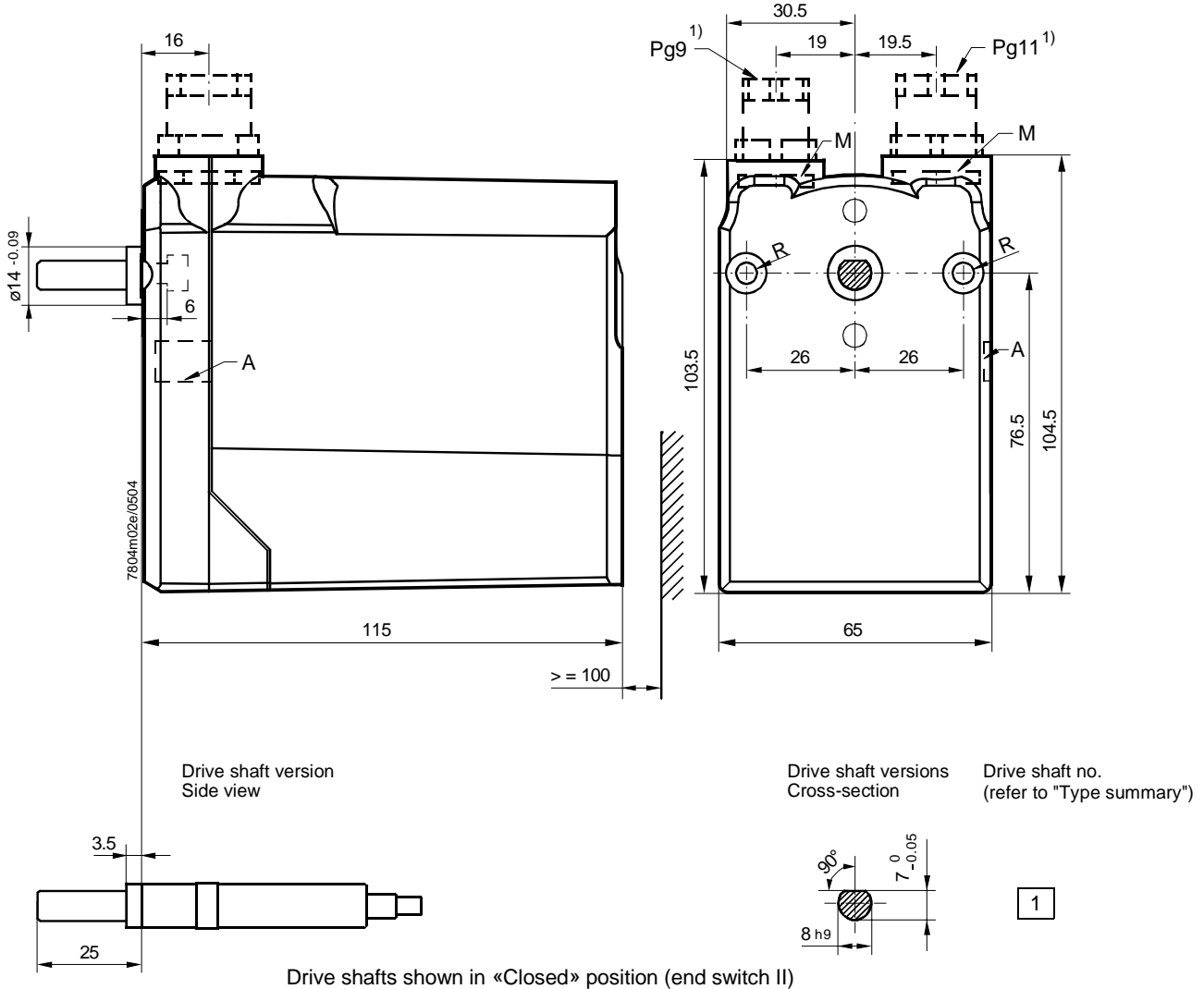

Drive shafts shown in «Closed» position (end switch II)

- A Knockout hole for loose cable entry
- R Through-hole 5.3 mm dia.
Fixing positions matched to Conectron LKS 160 and Berger STA
- M Pg nuts (not included in supply; for type reference, refer to «Technical data»)
- 1) Not included in supply

По вопросам продаж и поддержки обращайтесь:

Алматы (7273)495-231
 Ангарск (3955)60-70-56
 Архангельск (8182)63-90-72
 Астрахань (8512)99-46-04
 Барнаул (3852)73-04-60
 Белгород (4722)40-23-64
 Благовещенск (4162)22-76-07
 Брянск (4832)59-03-52
 Владивосток (423)249-28-31
 Владикавказ (8672)28-90-48
 Владимир (4922)49-43-18
 Волгоград (844)278-03-48
 Вологда (8172)26-41-59
 Воронеж (473)204-51-73
 Екатеринбург (343)384-55-89
 Иваново (4932)77-34-06
 Ижевск (3412)26-03-58
 Иркутск (395)279-98-46
 Казань (843)206-01-48

Калининград (4012)72-03-81
 Калуга (4842)92-23-67
 Кемерово (3842)65-04-62
 Киров (8332)68-02-04
 Коломна (4966)23-41-49
 Кострома (4942)77-07-48
 Краснодар (861)203-40-90
 Красноярск (391)204-63-61
 Курган (3522)50-90-47
 Курск (4712)77-13-04
 Липецк (4742)52-20-81
 Магнитогорск (3519)55-03-13
 Москва (495)268-04-70
 Мурманск (8152)59-64-93
 Набережные Челны (8552)20-53-41
 Нижний Новгород (831)429-08-12
 Новокузнецк (3843)20-46-81
 Новосибирск (383)227-86-73
 Ноябрьск (3496)41-32-12

Омск (3812)21-46-40
 Орел (4862)44-53-42
 Оренбург (3532)37-68-04
 Пенза (8412)22-31-16
 Пермь (342)205-81-47
 Петрозаводск (8142)55-98-37
 Псков (8112)59-10-37
 Ростов-на-Дону (863)308-18-15
 Рязань (4912)46-61-64
 Самара (846)206-03-16
 Санкт-Петербург (812)309-46-40
 Саранск (8342)22-96-24
 Саратов (845)249-38-78
 Севастополь (8692)22-31-93
 Симферополь (3652)67-13-56
 Смоленск (4812)29-41-54
 Сочи (862)225-72-31
 Ставрополь (8652)20-65-13
 Сургут (3462)77-98-35

Сыктывкар (8212)25-95-17
 Тамбов (4752)50-40-97
 Тверь (4822)63-31-35
 Тольятти (8482)63-91-07
 Томск (3822)98-41-53
 Тула (4872)33-79-87
 Тюмень (3452)66-21-18
 Улан-Удэ (3012)59-97-51
 Ульяновск (8422)24-23-59
 Уфа (347)229-48-12
 Хабаровск (4212)92-98-04
 Чебоксары (8352)28-53-07
 Челябинск (351)202-03-61
 Череповец (8202)49-02-64
 Чита (3022)38-34-83
 Якутск (4112)23-90-97
 Ярославль (4852)69-52-93