



Electrical Actuators

SSD31..
SSD81..
SSD61..

for Combi-valve types VPI45...

- **SSD31..** operating voltage AC 230 V 3-position control signal
- **SSD81..** operating voltage AC 24 V 3-position control signal
- **SSD61..** operating voltage AC/DC 24 V DC 0...10 V control signal
- **Nominal force > 250 N**
- **Automatic identification of valve stroke**
- **Direct mounting with union nut, no tools required**
- **Basic types complete with plug-in connecting cable, length 1.5 m**
- **Optional cable types**
 - cable length 1.5 m, 2.5 m and 4.5 m
 - halogen-free cables
- **Manual override and position indication**
- **Parallel connection of multiple actuators possible**

Use

For operation of Siemens valves VPI45.. for water-side control of hot and cooling water in heating, ventilation and air conditioning systems.

Архангельск (8182)63-90-72
Астана +7(7172)727-132
Белгород (4722)40-23-64
Брянск (4832)59-03-52
Владивосток (423)249-28-31
Волгоград (844)278-03-48
Вологда (8172)26-41-59
Воронеж (473)204-51-73
Екатеринбург (343)384-55-89
Иваново (4932)77-34-06
Ижевск (3412)26-03-58
Казань (843)206-01-48

Калининград (4012)72-03-81
Калуга (4842)92-23-67
Кемерово (3842)65-04-62
Киров (8332)68-02-04
Краснодар (861)203-40-90
Красноярск (391)204-63-61
Курск (4712)77-13-04
Липецк (4742)52-20-81
Магнитогорск (3519)55-03-13
Москва (495)268-04-70
Мурманск (8152)59-64-93
Набережные Челны (8552)20-53-41

Нижний Новгород (831)429-08-12
Новокузнецк (3843)20-46-81
Новосибирск (383)227-86-73
Орел (4862)44-53-42
Оренбург (3532)37-68-04
Пенза (8412)22-31-16
Пермь (342)205-81-47
Ростов-на-Дону (863)308-18-15
Рязань (4912)46-61-64
Самара (846)206-03-16
Санкт-Петербург (812)309-46-40
Саратов (845)249-38-78

Смоленск (4812)29-41-54
Сочи (862)225-72-31
Ставрополь (8652)20-65-13
Тверь (4822)63-31-35
Томск (3822)98-41-53
Тула (4872)74-02-29
Тюмень (3452)66-21-18
Ульяновск (8422)24-23-59
Уфа (347)229-48-12
Челябинск (351)202-03-61
Череповец (8202)49-02-64
Ярославль (4852)69-52-93

Type summary

Standard versions

Type reference	Operating voltage	Positioning time at 50 Hz	Control signal	Connecting cable
SSD31	AC 230 V	150 s	3-position	1.5 m
SSD31/00 ¹⁾				no cable
SSD81	AC 24 V			1.5 m
SSD81/00 ¹⁾				no cable
SSD61	AC / DC 24 V	75 s	DC 0...10 V	1.5 m
SSD61/00 ¹⁾				no cable

¹⁾ Available cable lengths or terminal block connectors refer to «Accessories», page 2

SSD81..., SSD61.. are UL and cUL approved.

Accessories

Type reference	Description	Operating voltage	Control signal
ASY3L15	Connecting cable 1.5 m	AC 230 V	3-position
ASY3L25	Connecting cable 2.5 m		
ASY3L45	Connecting cable 4.5 m		
ASY6L15	Connecting cable 1.5 m	AC / DC 24 V	DC 0...10 V
ASY6L25	Connecting cable 2.5 m		
ASY6L45	Connecting cable 4.5 m		
ASY6L45HF	Connecting cable 4.5 m, halogen-free, VDE 0207-24		
ASY8L15	Connecting cable 1.5 m	AC 24 V	3-position
ASY8L25	Connecting cable 2.5 m		
ASY8L25B	Connecting cable 2.5 m with Batigyr connector		
ASY8L45	Connecting cable 4.5 m		
ASY8L45HF	Connecting cable 4.5 m, halogen-free, VDE 0207-24		
ASY98	Retaining screw for terminal block connectors		
ASY99	Terminal block connector for 3-position actuator SSD81/00 (AC 24 V)		
ASY100	Terminal block connector for DC 0...10 V modulating actuators SSD61/00		

Ordering

When ordering, please give quantity, product name and type reference.

Example: 2 actuators without cable SSD81/00 and
2 terminal block connectors ASY99

Delivery

Actuators, valves and accessories are packed separately. Items are supplied individually packed.

Equipment combinations

Type reference	Valve type	\dot{V}_{100} [l/h]	PN class	Data sheet
VPI45..	Combi valves	75 ... 3000	PN25	N4853
VPI45..Q	Combi valves with P/T plugs			

\dot{V}_{100} = volumetric flow, in l/h, through the fully open valve (H_{100})

Function / mechanical design

When the actuator is driven by DC 0...10 V control voltage or by a 3-position signal, it produces a stroke which is transmitted to the valve stem.
The description of operation in this document applies to the valve versions which are fully closed when de-energized (NC valves).

3-position control signal SSD31../SSD81..

- Voltage at Y1: Stem extends Valve opens
- Voltage at Y2: Stem retracts Valve closes
- No voltage at Y1 and Y2: Actuator maintains its current position

DC 0...10 V control signal SSD61..

- The valve opens / closes in proportion to the control signal at Y.
- At DC 0 V, the valve is fully closed (A → AB).
- When power supply is removed, the actuator maintains its current position.

Features and benefits

- Plastic housing
- Locking-proof, maintenance-free gear train
- Manual override with hexagonal socket wrench 3 mm
- Reduced power consumption in the holding positions
- Load-dependent switch-off in the event of overload and in stroke end positions
- Parallel operation of 6 SSD31.., 24 SSD81.. and 10 SSD61.. possible, provided the controllers' output is sufficient
- Terminal block connectors for custom made cables available (only for use with AC 24 V and AC/DC 24 V actuators)
- Connecting cables with AC 24 V and AC 230 V connectors cannot be mixed up
- Halogen-free cables available

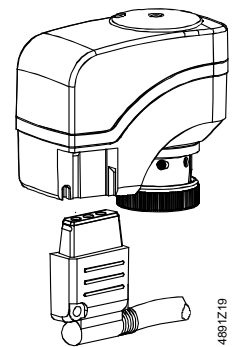

Accessories

Retaining screw ASY98



Type ASY98 to secure the cable connector

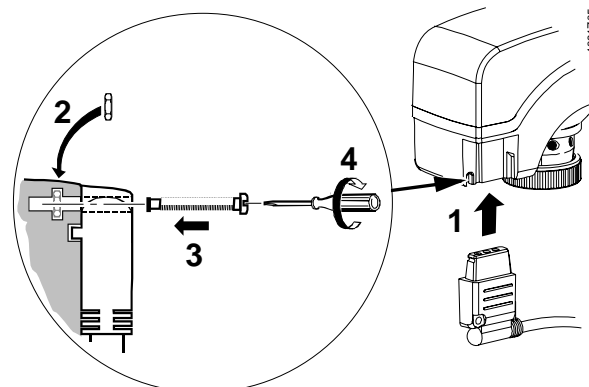

The cable connector snaps into position, but can be additionally secured with the retaining screw.

Terminal block connectors ASY99 ASY100

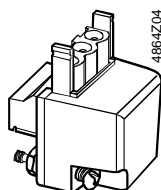

For special cable lengths of the AC 24 V and AC/DC 24 V actuators.

- Type ASY99 for 3-position actuators SSD81/00
- Type ASY100 for DC 0...10 V modulating actuators SSD61/00

The terminal block connectors are supplied complete with Mounting Instructions (74 319 0385 0).

Notes

Engineering

The actuators must be electrically connected in accordance with local regulations (refer to «Connection diagrams»), page 7.

⚠ Caution

Regulations and requirements to ensure the safety of people and property must be observed at all times!

The permissible temperatures (refer to «Technical data», page 6) must be observed. The connecting cable of the actuator may come into contact with the hot valve body, provided the temperature of the valve body does not exceed 80 °C.

Mounting

The Mounting Instructions 4 319 0644 0 are enclosed in the product packaging. Assembly is made with the union nut; no tools or adjustments are required. The actuator must be fitted in position 0 (also refer to «Manual override», page 5) without operating voltage.

In the case of actuators without connecting cable (SSD../00), the separately ordered terminal block connector and connecting cable must be fitted.

Orientation

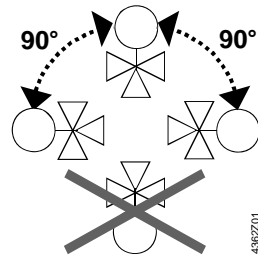

Commissioning

When commissioning, check wiring and the functioning of the actuator.

- Actuator stem extends (from position 0 to 1): Valve opens
- Actuator stem retracts (from position 1 to 0): Valve closes

Self-calibration

⚠ Caution

During commissioning and whenever the operating voltage is switched on, the SSD61.. runs a self-calibration routine. (Valve stroke 0 → Max. stroke → Setpoint). Never intervene manually in this process.

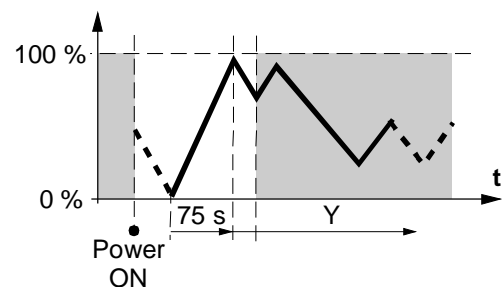

Note: Correct calibration is only possible

- with valve
- stroke > 1.5 mm

The second or third attempt at calibration occurs automatically after an 8-minute delay.

After three failed calibration attempts the actuator stem remains in the extended position and the VPI45.. valves are opened.

For valves with strokes < 1.5 mm, the actuator/valve combination locks after three failed calibration attempts.

Manual override

A 3 mm hexagonal socket wrench can be used to move the actuator to any position between 0 and 1. If a control signal from the controller is present, then this takes priority in determining the position.

Note To retain the manually set position, unplug the connecting cable or switch off power and the control signal.

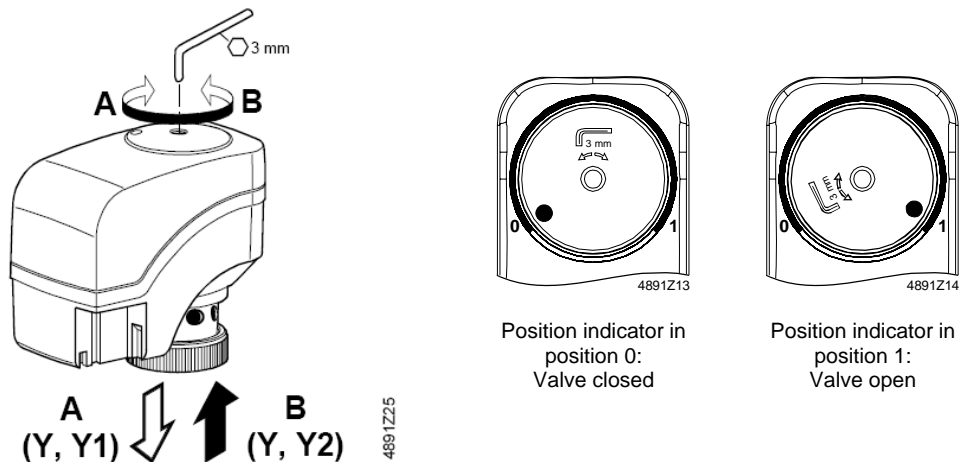

Maintenance

The actuators are maintenance-free.

When carrying out service work on the plant, following must be noted:



- Turn power off (e.g. remove the plug)
- If necessary, disconnect electrical connections from the terminals
- The actuator must be commissioned only with a correctly mounted valve in place!

Repair

SSD.. actuators cannot be repaired; the complete unit must be replaced.
Broken connecting cables can be replaced, see «Accessories», page 2.

Disposal



The device must not be disposed of together with domestic waste. This applies in particular to the PCB.

Legislation may demand special handling of certain components, or it may be sensible from an ecological point of view.

Current local legislation must be observed.

Warranty

The technical data given for these applications is valid only when the actuators are used with the Siemens valves listed under «Equipment combinations», page 2.

The use of the SSD.. actuators in conjunction with third-party valves invalidates any warranty offered by Siemens Switzerland Ltd / HVAC Products.

Technical data

		SSD31..	SSD81..	SSD61..
Power supply	Operating voltage	AC 230 V	AC 24 V	AC 24 V or DC 24 V
	Voltage tolerance	± 15 %	± 20 %	± 20 % ± 25 %
	Rated frequency	50 / 60 Hz		
	Max. power consumption	6 VA	0.8 VA	2.5 VA
Control	△ Fuse for incoming cable	2 A, quickblow		
	Control signal	3-position		DC 0...10 V
	Input impedance for DC 0...10 V			> 100 kOhm
	Positioning accuracy for DC 0...10 V	< 2 % of nominal stroke		
	Parallel operation (number of actuators) ¹⁾	max. 6	max. 24	max. 10
Functional data	Run time for 5.5 mm stroke at 50 Hz	150 s		75 s
	Nominal stroke	5.5 mm		
	Nominal force	> 250 N		
	Perm. temperature of medium in the connected valve	1...110°C		
Electrical connections	Connecting cable of basic types ASY 99, ASY100	1.5 m 3-core to EN 60320 / IEC 60227		
	cable diameter	< 5 mm		
	maximal wire cross section	0.5 mm ²		
Standards	Meets requirements for CE marking: EMC directive	2004/108/EC		
	Immunity	EN 61000-6-2	Industrial ²⁾	
	Emission	EN 61000-6-3	Residential	
	Low voltage directive	2006/95/EC		
	Electrical safety	EN 60730-1		
	Protection class to EN 60730	II	III	
	Contamination level	EN 60730, Class 2		
	Housing protection Upright to horizontal	IP40 to EN 60529		
	UL approbation	UL 873		
	cUL approbation	C22.2 No. 24-93		
Environmental compatibility	ISO 14001 (Environment) ISO 9001 (Quality) SN 36350 (Environmentally compatible products) RL 2002/95/EG (RoHS)			
Dimensions / weight	Dimensions	refer to «Dimensions», page 8		
	Coupling thread to valve	union nut M30x1.5 mm		
	Weight	0.35 kg		
Housing colors	Base and cover	RAL 7035 light gray		

< 5 mm
0,5 mm²

¹⁾ Provided the controllers' output is sufficient

²⁾ Transformer 160 VA (e.g. Siemens 4AM3842-4TN00-0EA0) for AC 24 V actuators

General ambient conditions

	Operation EN 60721-3-3	Transport EN 60721-3-2	Storage EN 60721-3-1
Environmental conditions	Class 3K3	Class 2K3	Class 1K3
Temperature	+1...+50 °C	-25...+70 °C	-5...+50 °C
Humidity	5...85 % r.h.	< 95 % r.h.	5...95 % r.h.

Connecting cable

SSD31..

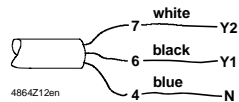

Control signal CLOSE (AC 230 V)
Control signal OPEN (AC 230 V)
Neutral

SSD81..

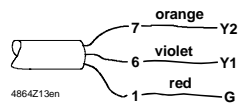

Control signal CLOSE (AC 24 V)
Control signal OPEN (AC 24 V)
System potential AC 24 V

SSD61..

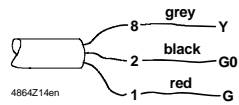

Control signal DC 0 ... 10 V
System neutral (- at DC 24 V)
System potential AC 24 V (+ at DC 24 V)

Connection terminals

ASY99
for SSD81..

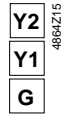

Control signal CLOSE
Control signal OPEN
System potential AC 24 V

ASY100
for SSD61..

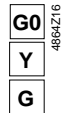

System neutral
Control signal DC 0 ... 10 V
System potential AC/DC 24 V

Connection diagrams

SSD31..

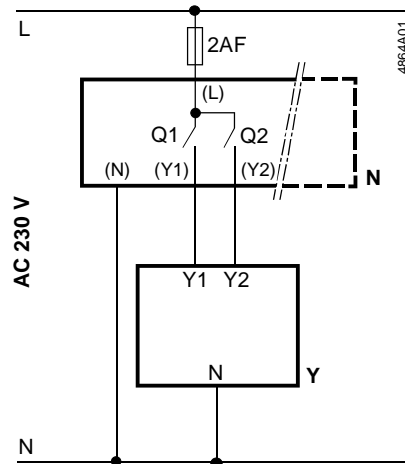

N Controller
Y Actuator
L System potential AC 230 V
N System neutral
Y1, Y2 Control signal OPEN, CLOSE
Q1, Q2 Controller contacts

SSD81..

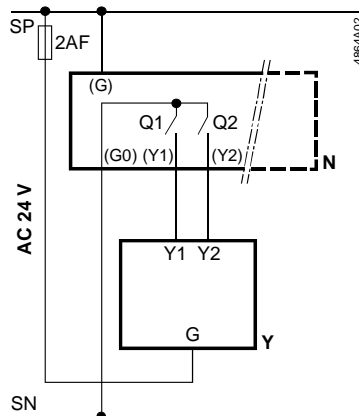

N Controller
Y Actuator
SP, G System potential AC 24 V
SN, G0 System neutral
Y1, Y2 Control signal OPEN, CLOSE
Q1, Q2 Controller contacts

SSD61..

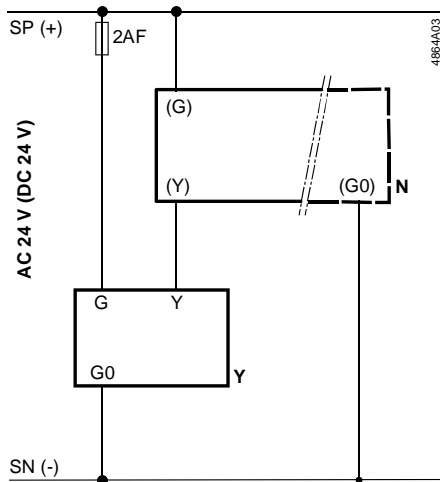

- N Controller
- Y Actuator
- SP, G System potential AC/DC 24 V
- SN, G0 System neutral
- Y Control signal

Dimensions

All dimensions in mm

Actuator

- SSD31..
- SSD81..
- SSD61..

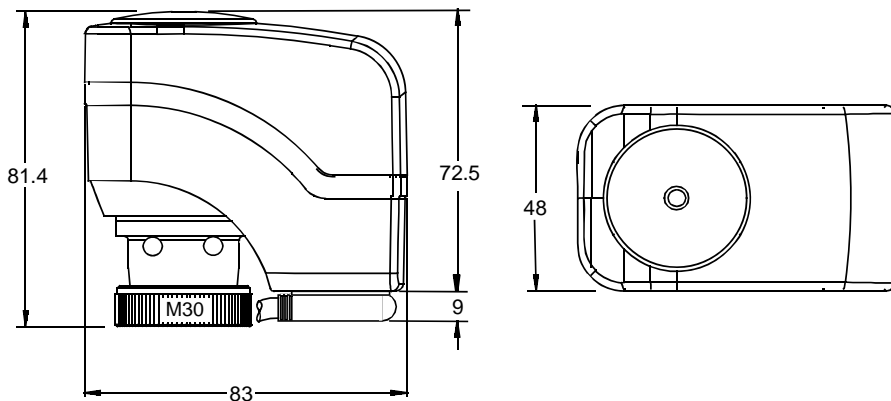

Архангельск (8182)63-90-72
 Астана +7(7172)727-132
 Белгород (4722)40-23-64
 Брянск (4832)59-03-52
 Владивосток (423)249-28-31
 Волгоград (844)278-03-48
 Вологда (8172)26-41-59
 Воронеж (473)204-51-73
 Екатеринбург (343)384-55-89
 Иваново (4932)77-34-06
 Ижевск (3412)26-03-58
 Казань (843)206-01-48

Калининград (4012)72-03-81
 Калуга (4842)92-23-67
 Кемерово (3842)65-04-62
 Киров (8332)68-02-04
 Краснодар (861)203-40-90
 Красноярск (391)204-63-61
 Курск (4712)77-13-04
 Липецк (4742)52-20-81
 Магнитогорск (3519)55-03-13
 Москва (495)268-04-70
 Мурманск (8152)59-64-93
 Набережные Челны (8552)20-53-41

Нижний Новгород (831)429-08-12
 Новокузнецк (3843)20-46-81
 Новосибирск (383)227-86-73
 Орел (4862)44-53-42
 Оренбург (3532)37-68-04
 Пенза (8412)22-31-16
 Пермь (342)205-81-47
 Ростов-на-Дону (863)308-18-15
 Рязань (4912)46-61-64
 Самара (846)206-03-16
 Санкт-Петербург (812)309-46-40
 Саратов (845)249-38-78

Смоленск (4812)29-41-54
 Сочи (862)225-72-31
 Ставрополь (8652)20-65-13
 Тверь (4822)63-31-35
 Томск (3822)98-41-53
 Тула (4872)74-02-29
 Тюмень (3452)66-21-18
 Ульяновск (8422)24-23-59
 Уфа (347)229-48-12
 Челябинск (351)202-03-61
 Череповец (8202)49-02-64
 Ярославль (4852)69-52-93